

# REMOTE VFO

(080165)

Manual #183-36  
Price \$1.00

## TABLE OF CONTENTS

|              |       |                                 |
|--------------|-------|---------------------------------|
| SECTION I    | ----- | Unpacking and damage claims     |
| SECTION II   | ----- | Installation                    |
| SECTION III  | ----- | Operation                       |
| SECTION IV   | ----- | Alignment                       |
| SECTION V    | ----- | Schematic, Voltage - Resistance |
| SECTION VI   | ----- | Parts List                      |
| SECTION VII  | ----- | Service information             |
| SECTION VIII | ----- | Warranty                        |

## SECTION I

1-1 It is assumed the purchaser has the unit removed from the carton by the time this manual has been read. NOTE! Some tubes and parts may be packed internally and other precautions will be necessary before attempting to apply power. Take notice of any notes or tags relating to parts packaging.

1-2 **DAMAGE:** This equipment has been carefully packed for safe arrival IF PROPERLY HANDLED EN ROUTE.

### (a) OBVIOUS DAMAGE

If the carton showed signs of rough handling, you should have made such notation on the delivering carrier's receipt. If inspection shows obvious damage such as loose parts, broken parts, etc., the delivering carrier must be contacted immediately and a joint inspection made with this carrier's agent. The joint inspection is NOT a claim but an acknowledgement that the equipment was damaged. The form does not assign responsibility for the damage, but prepares the foundation on which to file a claim. The carrier will then acknowledge or decline the claim at their main office and a local agent may not decline to enter a claim. If the shipment was parcel post, contact your local postmaster for the necessary forms and he will help you enter the claim.

### (b) HIDDEN DAMAGE

In many cases the carton may not be damaged but the equipment may suffer internal damage not obvious on delivery of the shipment. The procedure for filing the claim would be the same as above.

Remember, the responsibility for safe delivery rests with the carrier. The responsibility in obtaining reimbursement for damage rests with YOU. Prompt action on your part will speed adjustments. Our warranty in no way covers malfunction or damage which is a result of improper handling by a carrier. Under no circumstances should you return merchandise to your dealer before instigating the necessary forms. To do so can jeopardize your investment and the costs of necessary repairs may be a burden you will have to assume. After joint inspection forms have been completed, contact your dealer for assistance.

## SECTION II

2-1---The REMOTE VFO is designed to be used with the GALAXY III, the V, and we anticipate retaining it's compatibility with future products we may introduce later. Installation is simple and consists of connecting the VFO main power and control cable to socket J1 on the rear panel of the transceiver (after the factory installed jumper plug is removed from J1). Also, the small coax cable from the REMOTE VFO is routed through the small hole in the rear panel of the transceiver and plugs into the jack on the rear of the internal transceiver VFO assembly. See Page 8 of the transceiver for location in the drawing. On the rear of the unit there is a small phone jack. If you desire to use the "PHONE" jack on the front panel of the REMOTE VFO, you should plug your speaker into this rather than on the transceiver. The speaker will be silenced when a head-phone plug is inserted.

## SECTION III

3-1 On the panel of the REMOTE VFO there is a function switch with four positions. The positions are: STDBY (standby), REC. (receive), TRANS-REC (transceive) and TRANS(transmit). These positions indicate how the REMOTE VFO will function when the switch is in one of these positions. For example: When in STDBY on the REMOTE VFO the VFO dial on the GALAXY selects the desired frequency on both transmitting and receiving. When the REMOTE VFO switch is on REC. its dial will control the received signals and the GALAXY VFO dial will still control the transmitting frequency. When on TRANS-REC, the REMOTE VFO dial will select the frequency on both transmitting and receiving. When on TRANS. the REMOTE VFO dial control transmitted frequency and the GALAXY dial the received frequency. When in STDBY the filament circuit of the REMOTE VFO remains on and ready to operate.

As the above indicates, this arrangement is extremely flexible. It permits you to listen in the DX band and still transmit in the assigned USA band, or vice versa if you are not a USA station. Also, it permits quick switching between two QSO's to monitor, to transmit, or to transceive. It is also handy to use the REMOTE VFO dial on REC position to check nearby frequencies for a clear spot to QSY.

For quick and positive identification as to how the REMOTE VFO is switched at a given time, we have provided two illuminated colored indicators. One is marked T and the other R. On REC the R indicator will light. On TRANS the T indicator will light. On TRANS-REC both T & R will light.

A CAL ADJ knob is provided for slight corrections of dial frequency, the same as on the GALAXY.

Since the REMOTE VFO is powered from the GALAXY, it is conceivable to use it mobile. It may not be mounted further away from the transceiver than the cables supplied will reach, nor may the cables be extended. However, in some cases this may provide a desirable arrangement where the transceiver might have to be mounted to the far right of the driver so as to make it inconvenient to reach the dial. In this case, the REMOTE VFO could be placed nearer the driver and convenient tuning accomplished across a small segment of the band for which the GALAXY is tuned. -- This would be especially convenient for cars with a console divider between the front seats.

## SECTION IV

### 4-1 External VFO Alignment

Set Galaxy controls as follows: (Remote VFO attached)

- (a) RF full clockwise
- (b) Function switch to Cal.

Note: If there is no plug-in crystal calibrator in unit any other accurate frequency source at 3.500 and 4.000 mc. may be used.

- (c) Load control - 10 o'clock
- (d) Plate control - 2 o'clock
- (e) Bandswitch - 3.5 to 4.0 mc.
- (f) Excitor control - 10 o'clock
- (g) Sideband Switch - SB-1
- (h) Cal ADJ - Midrange

Set REMOTE VFO controls as follows:

- (a) Function Switch to REC.
- (b) Main tuning Dial - 4.000 mc.

Adjust main tuning dial until calibrator is heard. (check to see if this is the 4.0 mc. beat note with signal generator)

Adjust L-1 and main tuning dial until the calibrator zero beat occurs at 4.0 mc.

Adjust main tuning dial to 3.5 mc. Rock main tuning dial until calibrator is heard.

Adjust C-8 and main tuning dial until the calibrator zero beat occurs at 3.5 mc.

Repeat steps 5 through 8 until calibrator zero occurs at 3.500 and 4.000 mc.

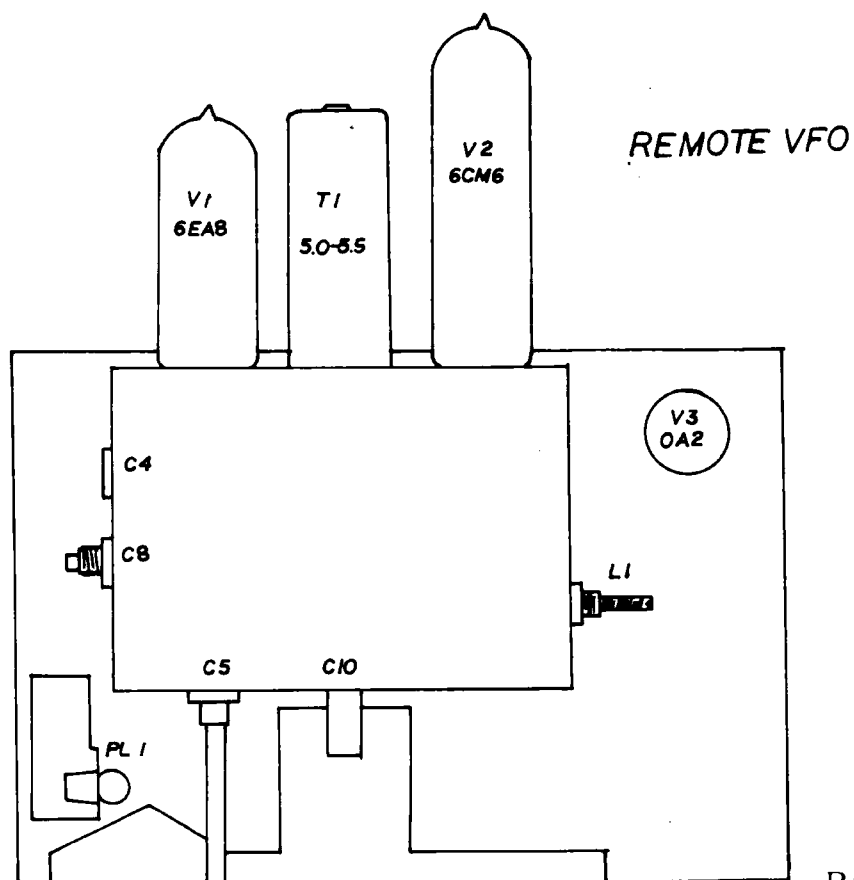

SECTION V

5-1 Schematic

REMOTE VFO

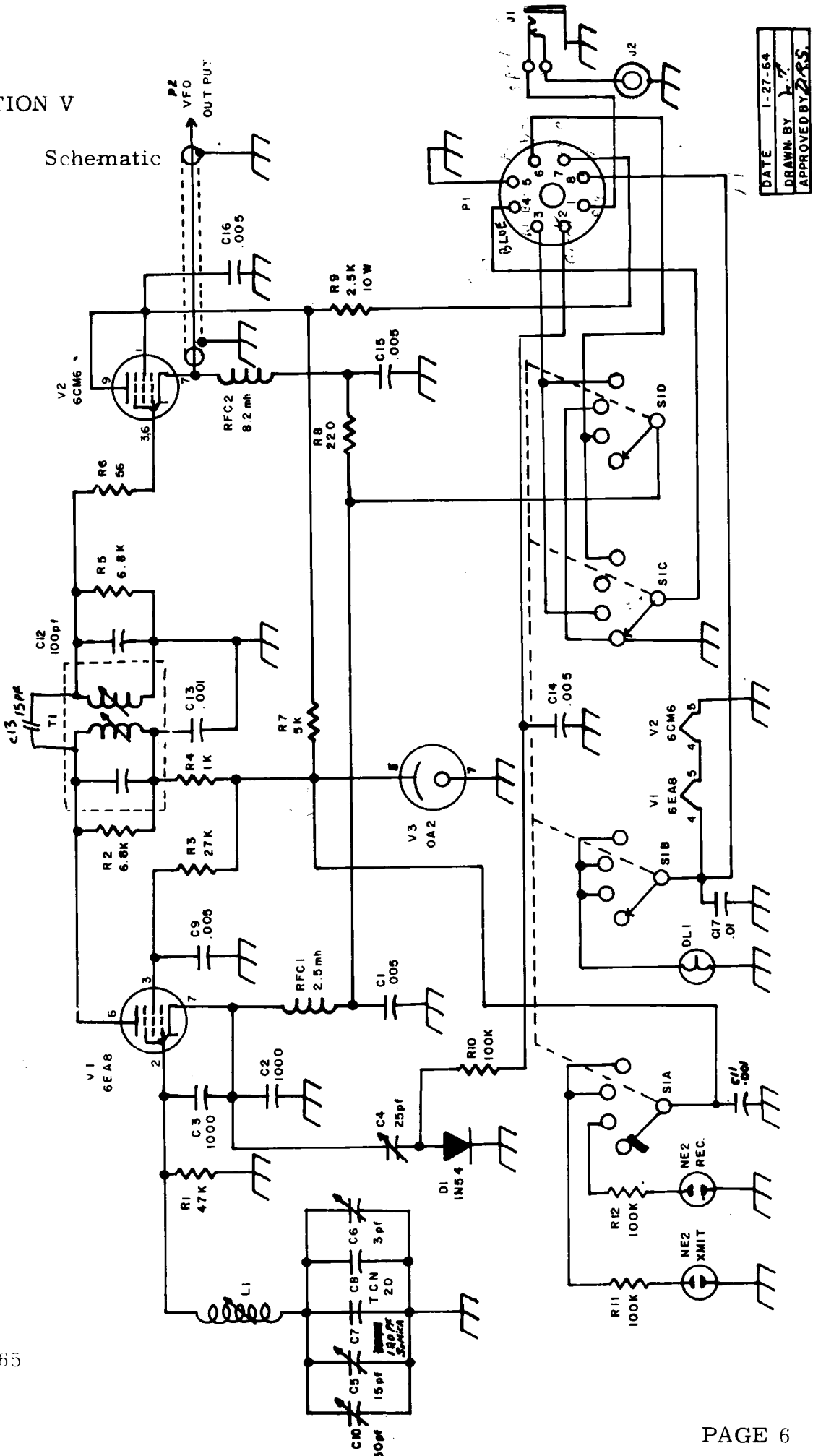

|             |         |
|-------------|---------|
| DATE        | 1-27-64 |
| DRAWN BY    | J.P.    |
| APPROVED BY | Z.R.S.  |

## SECTION V

5-2

## VOLTAGE CHART

## External VFO

## Function Switch Standby

| Pin | 1       | 2  | 3   | 4    | 5     | 6   | 7  | 8  | 9       |
|-----|---------|----|-----|------|-------|-----|----|----|---------|
| V1  | NC      | 0  | 145 | 12AC | 6.0AC | 145 | 76 | NC | NC      |
| V2  | 285/280 | NC | NC  | 0    | 6.0AC | 0   | 78 | NC | 285/280 |
| V3  | NC      | NC | NC  | NC   | 150   | NC  | 0  |    |         |

## Function Switch Receive

| Pin | 1       | 2      | 3       | 4    | 5     | 6       | 7       | 8  | 9       |
|-----|---------|--------|---------|------|-------|---------|---------|----|---------|
| V1  | NC      | -2.8/0 | 110/.45 | 12AC | 6.0AC | 138/140 | .13/165 | NC | NC      |
| V2  | 180/260 | 0      | 0       | 0    | 6.0AC | 0       | 78/76   | 0  | 180/260 |
| V3  | NC      | NC     | NC      | 0    | 150   | NC      | 0       |    |         |

## Function Switch Transceive

| Pin | 1   | 2      | 3   | 4    | 5     | 6   | 7 | 8  | 9   |
|-----|-----|--------|-----|------|-------|-----|---|----|-----|
| V1  | NC  | -2.8/0 | 110 | 12AC | 6.0AC | 140 | 0 | NC | NC  |
| V2  | 200 | NC     | NC  | 0    | 6.0AC | 0   | 9 | NC | 200 |
| V3  | NC  | NC     | NC  | NC   | 150   | NC  | 0 |    |     |

## Function Switch Transmit

| Pin | 1       | 2    | 3       | 4    | 5     | 6       | 7     | 8  | 9       |
|-----|---------|------|---------|------|-------|---------|-------|----|---------|
| V1  | NC      | 0/-9 | 145/110 | 12AC | 6.0AC | 145/140 | 76/.2 | NC | NC      |
| V2  | 285/200 | NC   | NC      | 0    | 6.0AC | 0       | 80/9  | NC | 285/200 |
| V3  | NC      | NC   | NC      | NC   | 150   | NC      | 0     |    |         |

Note: All measurements are made from ground to point being measure. All cables are connected to GALAXY III Function switch positioned as stated on voltage chart. Where two voltages are shown, the top one is receive voltage, and the bottom is the transmit voltage. All measurements were made with a Hewlett Packard 410B VTVM.

(080165)

## SECTION V

5-3

## RESISTANCE CHART

## External VFO

| Pin | 1 | 2   | 3   | 4   | 5   | 6  | 7 | 8 | 9 |
|-----|---|-----|-----|-----|-----|----|---|---|---|
| V1  | * | 50K | *   | 4.8 | 2.4 | *  | * | * | * |
| V2  | * | *   | 50K | 0   | 2   | 55 | * | * | * |
| V3  | * | 0   | *   | 0   | *   | *  | 0 |   |   |

Note: Resistance should remain the same with function switch in any position.

## Resistance P1

## Function Switch Standby

| Pin | 1 | 2     | 3 | 4 | 5 | 6 | 7 | 8 |
|-----|---|-------|---|---|---|---|---|---|
| P1  | * | 1 meg | * | 0 | 0 | * | * | 6 |

## Function Switch Receive

| Pin | 1 | 2     | 3 | 4 | 5 | 6 | 7 | 8   |
|-----|---|-------|---|---|---|---|---|-----|
| P1  | * | 1 meg | * | * | 0 | * | * | 4.3 |

## Function Switch Transceive

| Pin | 1 | 2     | 3 | 4 | 5 | 6 | 7 | 8   |
|-----|---|-------|---|---|---|---|---|-----|
| P1  | * | 1 meg | * | * | 0 | * | * | 4.3 |

## Function Switch Transmit

| Pin | 1 | 2     | 3 | 4 | 5 | 6 | 7 | 8   |
|-----|---|-------|---|---|---|---|---|-----|
| P1  | * | 1 meg | * | * | 0 | * | * | 4.3 |

Note: All measurements are made from ground to point being measured. All cables disconnected from GALAXY. Function switch positioned as stated on resistance chart. All measurements were made with a Hewlett Packard 410B VTVM.

\* Indicates no continuity (open circuit)



## SECTION VI

6-1

## PARTS LIST

## External VFO

Capacitors

| <u>C No.</u> | <u>Description</u>      | <u>Part No</u> | <u>Price</u> |
|--------------|-------------------------|----------------|--------------|
| C1, C9, C14  |                         |                |              |
| C15, C16     | .005 600v ceramic       | 20-3           | \$ 0.15      |
| C2, C3       | 1000pf 500v Silver mica | 22-19          | 0.33         |
| C4           | 5-25 pf variable        | 26-6           | 0.81         |
| C5           | 15 pf variable          | 25-14          | 2.40         |
| C6           | 3 pf variable           | 25-19          | 1.50         |
| C7           | 120 pf. silver mica     | 22-12          | 0.30         |
| C8           | 20 pf TCN               | 20-41          | 0.35         |
| C10          | 50 pf variable          | 25-17          | 1.70         |
| C11, C13     | .001 1000v ceramic      | 20-24          | 0.15         |
| C17          | .01 600v ceramic        | 20-5           | 0.24         |
| C12          | 100 pf @1000v           | 20-23          | 0.15         |
| C13          | 15 pf.                  | 22-38          | 0.15         |

Diodes

| <u>D No.</u> |       |           |      |
|--------------|-------|-----------|------|
| D1           | IN54A | 112-IN54A | 0.95 |

Coils

|    |                               |       |      |
|----|-------------------------------|-------|------|
| L1 | 5.0-5.5 Mc VFO Coil (special) | 42-12 | 5.25 |
|----|-------------------------------|-------|------|

Resistors

|               |                  |        |      |
|---------------|------------------|--------|------|
| R1            | 47K 1/2 watt     | 10-13  | 0.12 |
| R2, R5        | 6.8K 1/2 watt    | 10-15  | 0.12 |
| R3            | 27K 1/2 watt     | 10-14  | 0.12 |
| R4            | 1K 1/2 watt      | 10-42  | 0.12 |
| R6            | 56 ohm 1/2 watt  | 10-74  | 0.12 |
| R7            | 5K 10 watt       | 11-5D  | 0.36 |
| R8            | 220 ohm 1/2 watt | 10-58  | 0.12 |
| R9            | 2.5K 10 watt     | 11-10D | 0.36 |
| R10, R11, R12 | 100K 1/2 watt    | 10-32  | 0.12 |

Chokes

| <u>RFC No.</u> |        |      |      |
|----------------|--------|------|------|
| RFC-1          | 2.5 mh | 30-9 | 0.42 |
| RFC-2          | 8.2 mh | 30-5 | 0.35 |

## SECTION VI

6-1 (Cont)

## PARTS LIST

## External VFO

Transformer

| <u>T No.</u> | <u>Description</u>      | <u>Part No.</u> | <u>Price</u> |
|--------------|-------------------------|-----------------|--------------|
| T1           | 5.0-5.5 mc. Transformer | 76-6            | \$ 0.96      |

Tubes

| <u>V No.</u> |                   |                       |      |
|--------------|-------------------|-----------------------|------|
| V1           | 6EA8              | 110-6EA8              | 1.60 |
| V2           | 6CM <del>86</del> | 110-6CM <del>86</del> | 2.13 |
| V3           | OA2               | 110-OA2               | 1.32 |

Miscellaneous

|     |                                |               |      |
|-----|--------------------------------|---------------|------|
|     | VFO Cabinet                    | 140-14        | 7.45 |
|     | Front Panel                    | 141-13        | 6.03 |
|     | Jackson Ball Drive 13/32 shaft | 172-11A       | 1.20 |
|     | Jackson Ball Drive 9/16 shaft  | 172-11B       | 1.20 |
|     | 26 tooth gear                  | 151-2         | 1.35 |
|     | 52 tooth gear                  | 151-3         | 1.80 |
|     | Hairline                       | 172-19        | 2.35 |
|     | VFO dial escutcheon            | 130-14-1      | 0.35 |
|     | Large VFO tuning knob          | 130-14-2      | 0.35 |
|     | Small VFO tuning knob          | 130-14-3      | 0.30 |
|     | Function switch knob           | 130-14-7      | 0.35 |
|     | Front feet                     | 133-7, 133-15 | 0.10 |
|     | Rear feet                      | 133-7         | 0.05 |
|     | Cal. adjust knob               | 151-9         | 0.25 |
|     | Function switch                | 53-16         | 2.05 |
|     | VFO dial (2 color)             | 172-17        | 3.30 |
|     | Cable clamp                    | 133-13        | 0.05 |
|     | Transmit light NE2             | 113-B9NE2ER   | 0.90 |
|     | Receive light NE2              | 113-B9NE2EA   | 0.90 |
| DL1 | 12v dial light                 | 113-24        | 0.24 |
| P1  | 8 pin plug                     | 104-1         | 0.51 |
| P2  | Phone plug                     | 105-1         | 0.10 |
| J1  | Phone jack closed ckt.         | 102-2         | 0.37 |
| J2  | Phone jack                     | 100-4         | 0.10 |