

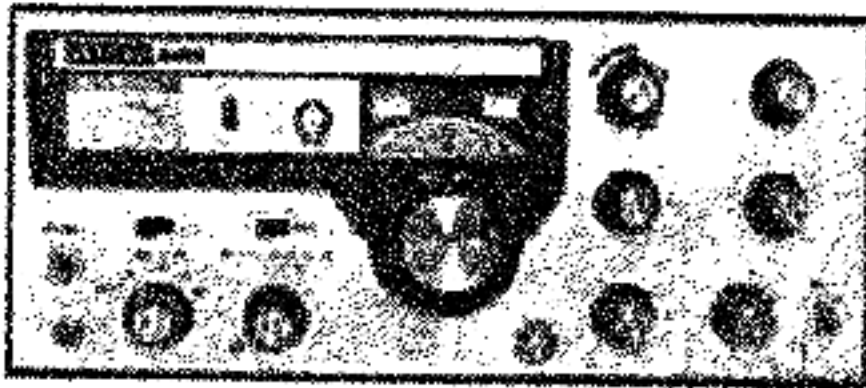

TEMPO ONE

SERVICE MANUAL



HENRY RADIO CO.

Downloaded by
RadioAmateur.EU

TEMPO ONE SERVICE MANUAL

ALIGNMENT PROCEDURE FOR THE TEMPO ONE

1. "Operate" switch in calibrate.
2. VFO dial at 300 KC.
3. "Function" switch in "Tune".
4. Grid at 12 o'clock.
5. AF and RF Gain at a level which will allow you to listen and also enable you to hear a 100 KC calibrated tone.
6. Put PO-IC-ALC select switch in IC position.
7. Clarifier off.
8. Mike gain at 9 o'clock.
9. VFO Select at "Normal".
10. PTT-VOX in PTT position.

Band Alignment for Receive

1. Band switch at 3.5. Align L7 and L12 for maximum "S" meter level or maximum calibrate signal.
2. Band switch to 7.0. Adjust TC-1 and TC-2 for maximum "S" meter reading or maximum calibrate signal. Also L5.
3. Band switch to 14.0. Adjust L10 and L15 for maximum "S" meter or maximum calibrate signal.
4. Band switch to 21.0. Adjust L9 and L14 and L4 for maximum "S" meter or calibrate signal.
5. *Bandswitch at 28.5. Adjust L3, L8 and L13 for maximum "S" meter reading or maximum calibrate signal.

*Note: If optional crystals were installed in 28.0, 29.0 or 29.5, do not adjust coils, but align respective trimmers TC203, TC205 and TC206 for maximum calibrate signal.

For this alignment, grid is set as follows:

28.0 grid at 9 o'clock - adjust TC203

29.0 grid at 2 o'clock - adjust TC205

29.5 grid at 4 o'clock - adjust TC206

These trimmers are located on the local oscillator board.

Transmitter alignment for the Tempo/One. All settings are the same except for the "Operate" switch.

1. "Operate" switch on Operate (no more than 15 seconds while tuning the transceiver.)
2. Peak all bands for maximum output on a 50 ohm dummy load or by observing the "S" meter.
3. 3.5 peak on dummy load for maximum output by peaking L7 and L12.
4. 7.0 peak for maximum output with TC1, TC2 and L5.
5. 14.0 peak for maximum output L10, L15.
6. 21.0 peak for maximum output L4, L9 and L14.
7. 28.5 peak for maximum output L3, L8 and L13.

Peak 28.0, 29.0 and 29.5 by peaking trimmers TC203, TC205 and TC206 in their respective grid positions.

TEMPO ONE INFORMATION

CHANGING THE BAND COVERAGE

The Tempo One is supplied for use on amateur bands. However, in cases where the user is willing to sacrifice one or more of the standard frequency ranges, he can substitute an adjacent, special range by changing the appropriate high frequency crystal.

The transition is easiest on the 10 meter band because there are 3 frequency ranges. On the Tempo One two of these ranges do not have the crystal supplied with the unit. For special frequencies of 1 MHz or less up or down from the amateur bands, such as MARS frequencies or others, you can achieve coverage by replacing the high frequency crystal with another crystal higher or lower in frequency.

The only exception to this rule on the Tempo One is the 500 KHz range below 3.5 MHz. This range is below the basic tuning capability of the equipment. You should remember however that the farther away from the amateur bands you get the more out of resonance you become. In receive this reduces the sensitivity of the receiver and in transmit the power output of the transmitter is reduced. Also on transmit if you are too far from the standard range, you will begin to burn out components.

For the Tempo One the crystals are below:

X201 for 7.0 MHz is 11.000 MHz standard crystal
X202 for 21.0 MHz is 33.500 MHz standard crystal
X203 for 28.0 MHz is 42.500 MHz standard crystal
X204 for 28.5 MHz is 43.000 MHz standard crystal
X205 for 29.0 MHz is 43.500 MHz standard crystal
X206 for 29.5 MHz is 44.000 MHz standard crystal

For 3.5 and 14 MHz you have to change the carrier crystal and this would change the frequency range of more than one band. For example 80, 15, and 10 use lower sideband. If you increase the frequency coverage on 80 you will also increase the frequency coverage on 15 and 10. And in the same way 40 and 20 use upper sideband. If you change the carrier crystal to change one band you will change the other. For this reason we do not recommend changing your frequency coverage on 80 or 20 meters.

Crystal Specifications: HC-18.

FIXED FREQUENCY TEMPO OPERATION WITH EXTERNAL VFO

3.5 - 4.0 MHz	$F_c = 9.0015 - F_r$	(LSB)
7.0 - 7.5 MHz	$F_c = F_r - 1.9985$	(USB)
14.0 - 14.5 MHz	$F_c = F_r - 8.9985$	(LSB)
21.0 - 21.5 MHz	$F_c = 26.0015 - F_r$	(LSB)
28.0 - 28.5 MHz	$F_c = 33.5015 - F_r$	(LSB)
28.5 - 29.0 MHz	$F_c = 34.0015 - F_r$	(LSB)
29.0 - 29.5 MHz	$F_c = 34.5015 - F_r$	(LSB)
29.5 - 30.0 MHz	$F_c = 35.0015 - F_r$	(LSB)

For reversed sideband operation, subtract 3 KHz from F_c .

F_c = Crystal Frequency

F_r = Desired Operating Frequency

Crystal Specifications: HC-6U.

A HIGH "Q" BANDPASS AUDIO CW FILTER FOR THE TEMPO ONE

You can easily make a very simple high "Q" band-pass audio filter for extra sharp CW reception in the Tempo One. A parallel resonant 300 Hz filter, consisting of one 88 mh coil and a 1 uf capacitor (at least 25 V, molded paper), is connected from the center terminal of VR1 (the AF Gain Control) to ground. The ground connection is used to switch the filter in and out. The switching can be made automatically using the back wafer of the function switch (S3h) or manually by adding a SPST switch to the back panel of the transceiver.

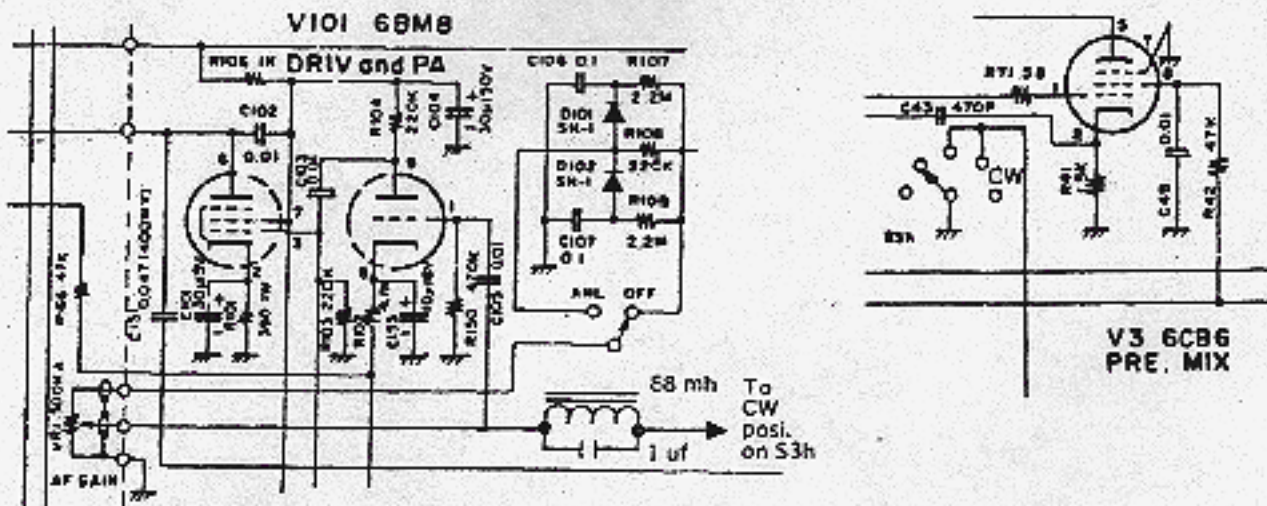

Downloaded by RadioAmateur.EU

TEMPO ONE DIAL ADJUSTMENTS

If adjustment of the Tempo One dial should become necessary, there are six possible conditions to be considered. A brief description of each and its remedy is outlined below.

First remove the Tempo from its cabinet.

CONDITION ONE: A dial will not turn, nor does the frequency change when the VFO tuning knob is turned.

PROBLEM: The set screws in the knob are loose.

REMEDY: Tighten the set screws.

CONDITION TWO: The VFO capacitor moves when the knob is turned, so the frequency changes, but the 50 KHz increment dial and the 1 KHz increment dials do not turn.

PROBLEM: The calibration knob below the VFO knob is incorrectly set or its associated brake is jammed against the 1 KHz readout dial.

REMEDY: Reset the calibrate knob or release the brake.

CONDITION THREE: The 1 KHz readout dial turns but the 50 KHz readout dial and the VFO capacitor do not turn.

PROBLEM: The set screws on the planetary drive have slipped.

REMEDY: (a) Tighten the set screws.

(b) Check the gears to be certain they are turning freely.

(c) Check the synchronization between the 1 KHz dial and the 50 KHz dial. If it is incorrect, proceed directly to the VFO SYNCHRONIZATION PROCEDURE.

REMEDY: First check to see that the 1 KHz dial synchronization (the zero on the 1 KHz dial corresponds to the 100, 200, 300, 400, or 500 on the 50 KHz dial) and that the 50 KHz dial is tightly fastened to the gear shaft. If either is not the case, proceed directly to the VFO DIAL SYNCHRONIZATION PROCEDURE. Otherwise merely tighten the set screws on the planetary drive.

CONDITION FOUR: Everything operates normally except the 50 KHz readout dial does not turn.

REMEDY: Perform steps 5 through 11 of the VFO SYNCHRONIZATION PROCEDURE.

CONDITION FIVE: Everything turns except the VFO capacitor so that the frequency does not change properly.

PROBLEM: The set screws inside the VFO cage are loose.

REMEDY: Remove the VFO cover and tighten the set screws on the shaft.

CONDITION SIX: There is mild or severe backlash between the 1 KHz dial and the VFO knob.

PROBLEM: The set screws that hold the flannel and metal washers against the 1 KHz dial are too loose.

REMEDY: (a) Remove the VFO knob.

(b) Remove the external VFO switch knob.

(c) Remove the phillips head screw under the VFO shaft.

(d) Remove the two phillips head screws from the back of the front panel. These screws are located at both extremes of the black VFO and "S" meter panel. Do not remove the screw that holds the pilot lamps.

(e) This black panel should now be free from the main front panel except for the wires that are attached to the meter switch.

(f) The metal and flannel washers that secure the 1 KHz dial should now be exposed.

(g) Gently tighten the screws that hold these washers. If these screws are too tight it will be difficult to calibrate the VFO.

(h) Replace the panel, screws and knobs.

VFO DIAL SYNCHRONIZATION PROCEDURE

- (1) Make sure that at least one set screw on the planetary drive is tight. At this point do not be concerned where the 1 KHz dial is set.
- (2) Manually move the 50 KHz dial to the right until it becomes tight and will not move on its shaft. Move the 50 KHz dial itself, not the frequency knob.
- (3) Connect the receiving antenna and apply the power to the set. Turn on the calibrator.
- (4) Turn the frequency knob counterclockwise (right window) until the red 50 KHz dial indicates zero. Calibrate signal may be heard at this point. If it can be heard, move ahead to step 11.
- (5) If the 50 KHz dial appears to be indicating incorrectly, continue turning the VFO knob until the capacitors become fully meshed.
- (6) Observe the indication on the 1 KHz dial. Turn the VFO knob clockwise approximately 90 KHz (as indicated on the 1 KHz dial) until the calibrate signal is heard and zero beat the signal.
- (7) Holding the top gear steady with your right thumb, loosen the 50 KHz dial.
- (8) Reset the beat calibrator with the VFO knob as necessary during the next two steps.
- (9) The 50 KHz dial should be loosened to the point where its turning becomes independent of the screw that is used to secure it. It may be necessary to rock the dial forward and backward to break the paint seal.
- (10) Now carefully rotate the 50 KHz dial to the right until you find the point that the screw becomes tight and the dial indicates zero KHz (indicated in red) at the pointer in the right hand window. Check to make sure that the VFO is still zero beat.

1 KHz DIAL SYNCHRONIZATION

- (11) Engage the calibrator brake. Rotate the VFO knob gently clockwise until it stops (do not force it beyond the lock). Now rotate it counterclockwise exactly one turn. Release the calibrator brake.
- (12) Check zero beat. Loosen the set screws on the planetary drive. The knob and the 1 KHz dial should now move independently of the 50 KHz dial and the VFO capacitors.
- (13) Set the 1 KHz dial at zero on the hair line.
- (14) Tighten the set screws on the planetary drive.

SERVICE NOTES - Kenwood and Tempo Equipment

- TS-511S** Matching final tubes. We have found it is not wise to replace only 1 of the final tubes. We suggest that you use RCA 6LQ6's. After installing two new tubes, adjust resting current in either upper or lower sideband modes for 40 ma. Leave set keyed without drive (modulation) for at least 15 minutes before proceeding. This will allow tubes to match themselves. Then proceed to neutralize.
- PS-511S** Presently over-fused (in our opinion). Using a 10 amp. fuse and we feel a 6 amp. fuse is better. If you have access to any PS-11S power supplies at the time of the sale, we suggest you install a 6 amp. fuse and instruct your customer to use 6 amp. fuses.
- Tempo One** - Recent deliveries have come through with a different antenna relay. Originally the antenna relay was a 100V relay (P/N 3254). Recent shipments of Tempo One transceivers use a 12VDC relay (P/N 3244). Should you get a request from your customers for an antenna relay, please determine which relay they need.

MODIFICATION FOR IMPROVED PRODUCT DETECTOR FOR THE TEMPO ONE

PURPOSE: To improve the linear characteristics of the product detector in the Tempo One, providing smoother voice reproduction.

PROCEDURE:

- (1) Unsolder and remove R110 and replace it with a 220 K ohm resistor.
- (2) Unsolder and remove L106 and replace it with a 270 ohm resistor.
- (3) Unsolder and remove R112 and replace it with a 10 K ohm resistor.
- (4) Connect a 560 K ohm resistor between V102, pin 7, and the junction of R126, R127, and R128. The modification is then complete.

COMPONENTS REQUIRED:

- | | |
|---|--|
| 1 | 220 K ohm carbon resistor, ½ watt, 10% |
| 1 | 270 ohm carbon resistor, ½ watt, 10% |
| 1 | 10 K ohm carbon resistor, ½ watt, 10% |
| 1 | 560 K ohm carbon resistor, ½ watt, 10% |

Downloaded by
RadioAmateur.EU

SCHEMATIC:

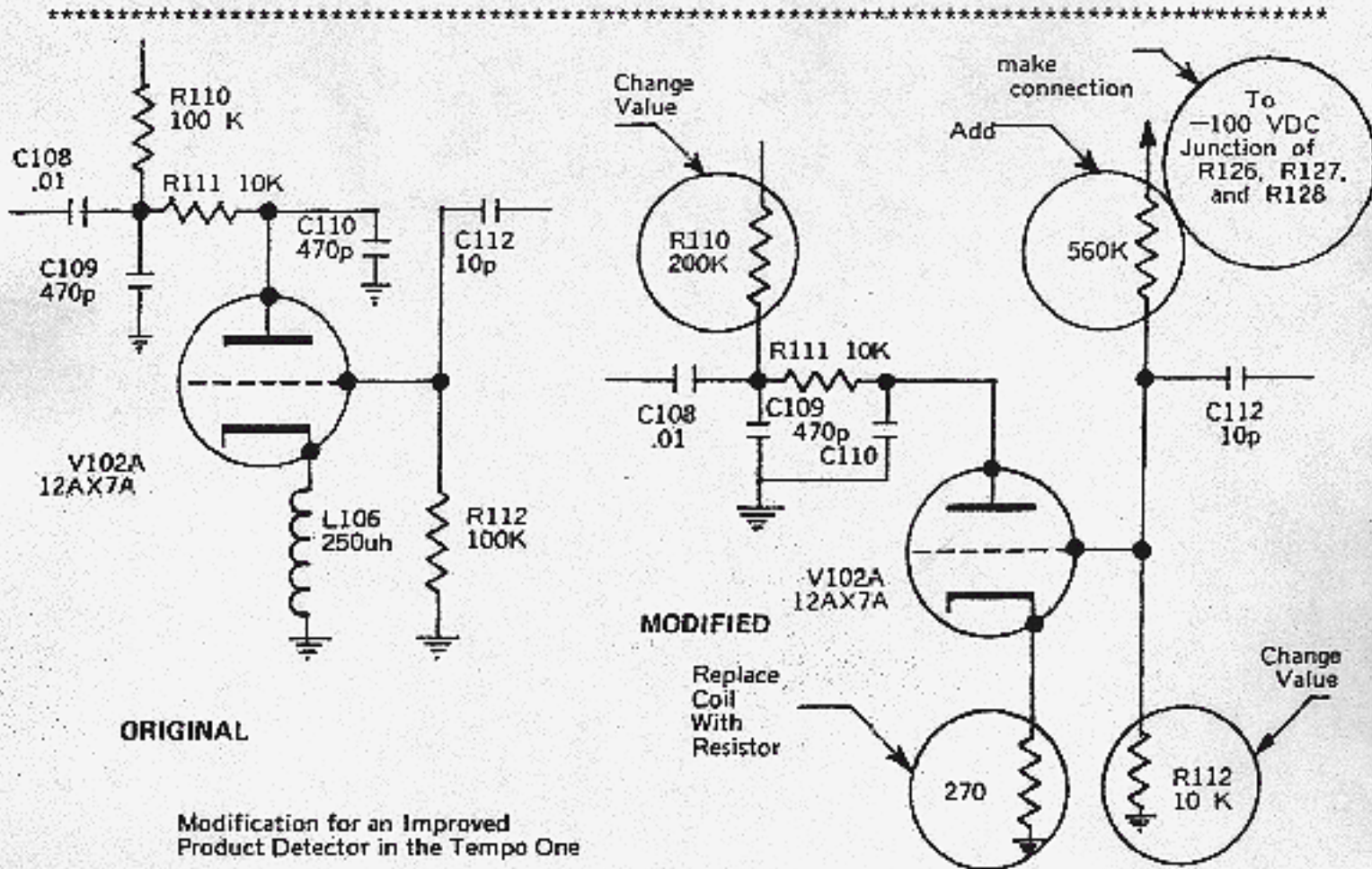

10 METER BAND CRYSTAL INSTALLATION FOR TEMPO ONE TRANSCEIVERS.

1. Install band switch at 28.5. Install 42.5 MHz crystal in the X203 position of Circuit Board PB 1041.
2. Remove the VFO plug at the rear of the Tempo One, and with a VTVM RF probe or wide-band oscilloscope, measure the RF injection voltage at Pin 2 of V3. Tune the TC 203 for maximum RF VOLTAGE. The reading will usually be .5 volts.
3. Put the VFO plug into the VFO jack on the back of the Tempo One. Tune the VFO oscillator to 200 (black dial scale). With your VFO frequency at 5.300 MHz, tune L3. Measure the heterodyne frequency on Pin 9 of V1 with a frequency counter. The frequency should be 42.5-5.300 which equals 37.200 MHz.
4. In the transmit mode, the frequency of 37.200 MHz mixes with the crystal carrier oscillator at 9.0015 MHz or 8.9985. Your transmitter should oscillate at 28.200 MHz. (37.200 MHz - 9.00 MHz = 28.200 MHz.)
5. Tune the signal generator to 28.200 MHz. Connect this to your Tempo One antenna. Tune grid, L8 and L3, for maximum beat.
6. Connect the Tempo One to a dummy load. Fine tune L13, L8, and L3 until an output of 150 watts is reached.

DO THE SAME PROCEDURE WITH ALL 10 METER CRYSTALL INSTALLATIONS.

AUDIO ROLL OFF MODIFICATION FOR THE TEMPO ONE

PURPOSE: To limit the high frequency response of the last audio stage in the Tempo One in order to improve the quality of the sound of a received voice signal.

PROCEDURE:

- (1) On the printed circuit board, break the path of the copper between V101 pin 3 and the junction of R103 and C103 by cutting the copper with a knife in two places and scraping off the copper between.
- (2) Solder the 22 K ohm, $\frac{1}{2}$ watt resistor between V101 pin 3 and the junction of R103 and C103.
- (3) Solder the .0033 mf capacitor between V101 pin 3 and any convenient ground connection. The modification is now complete.

COMPONENTS REQUIRED:

- 1 22 K ohm, $\frac{1}{2}$ watt, carbon resistor, 10%.
- 1 .0033 mf disc ceramic capacitor.

SCHEMATIC:

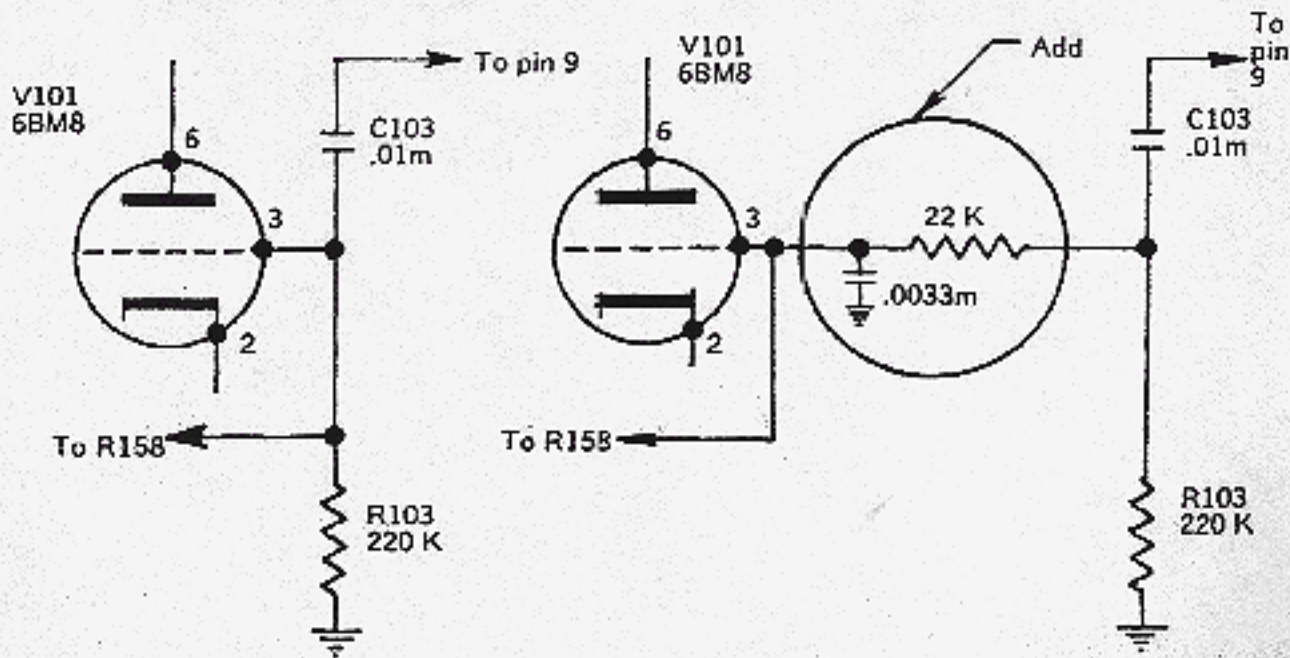

ORIGINAL

MODIFIED

Roll off Modification for the Tempo One

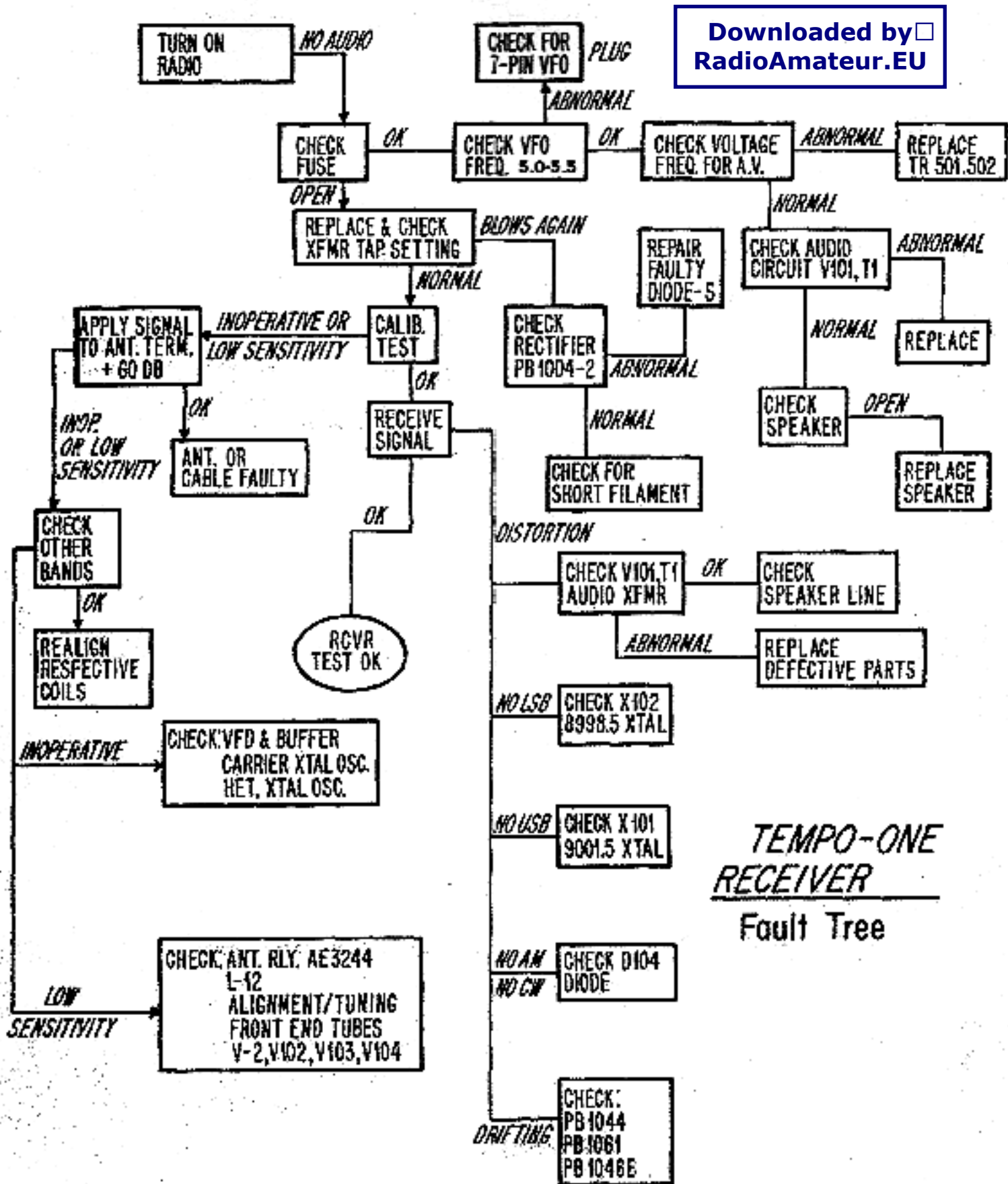

TEMPO-ONE RECEIVER
Fault Tree

TEMPO - ONE TRANSMITTER

Fault Tree

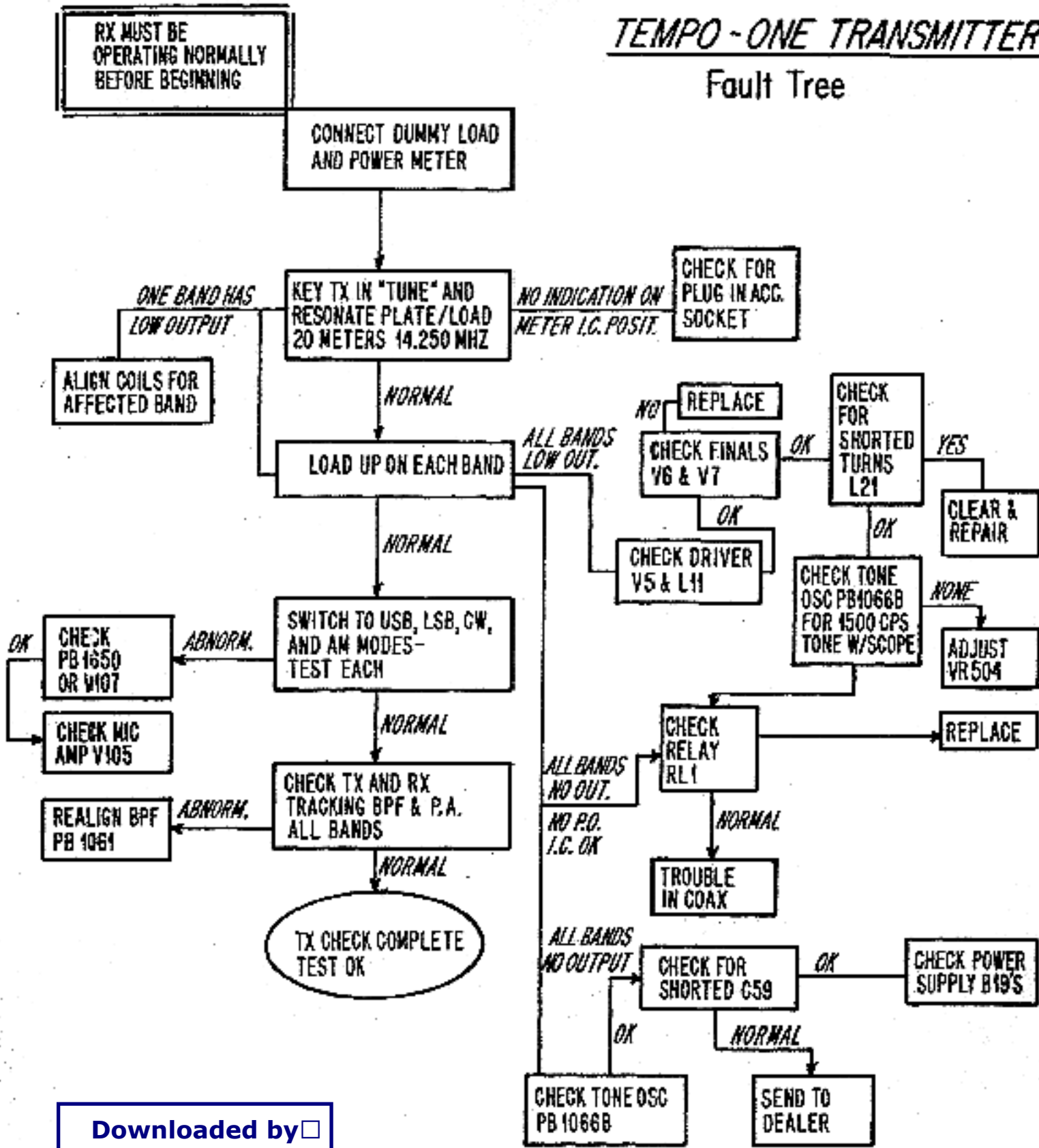

Downloaded by RadioAmateur.EU

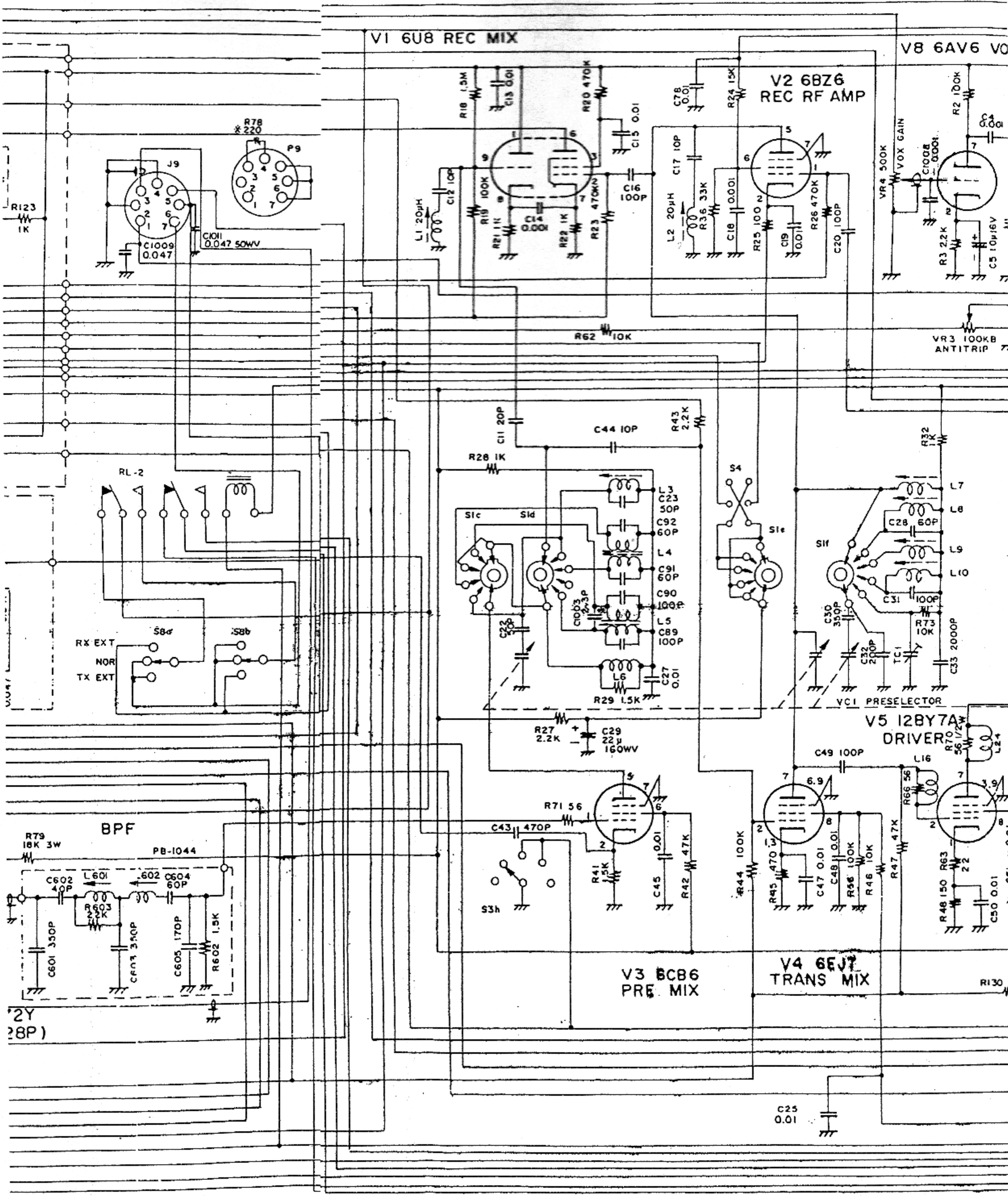

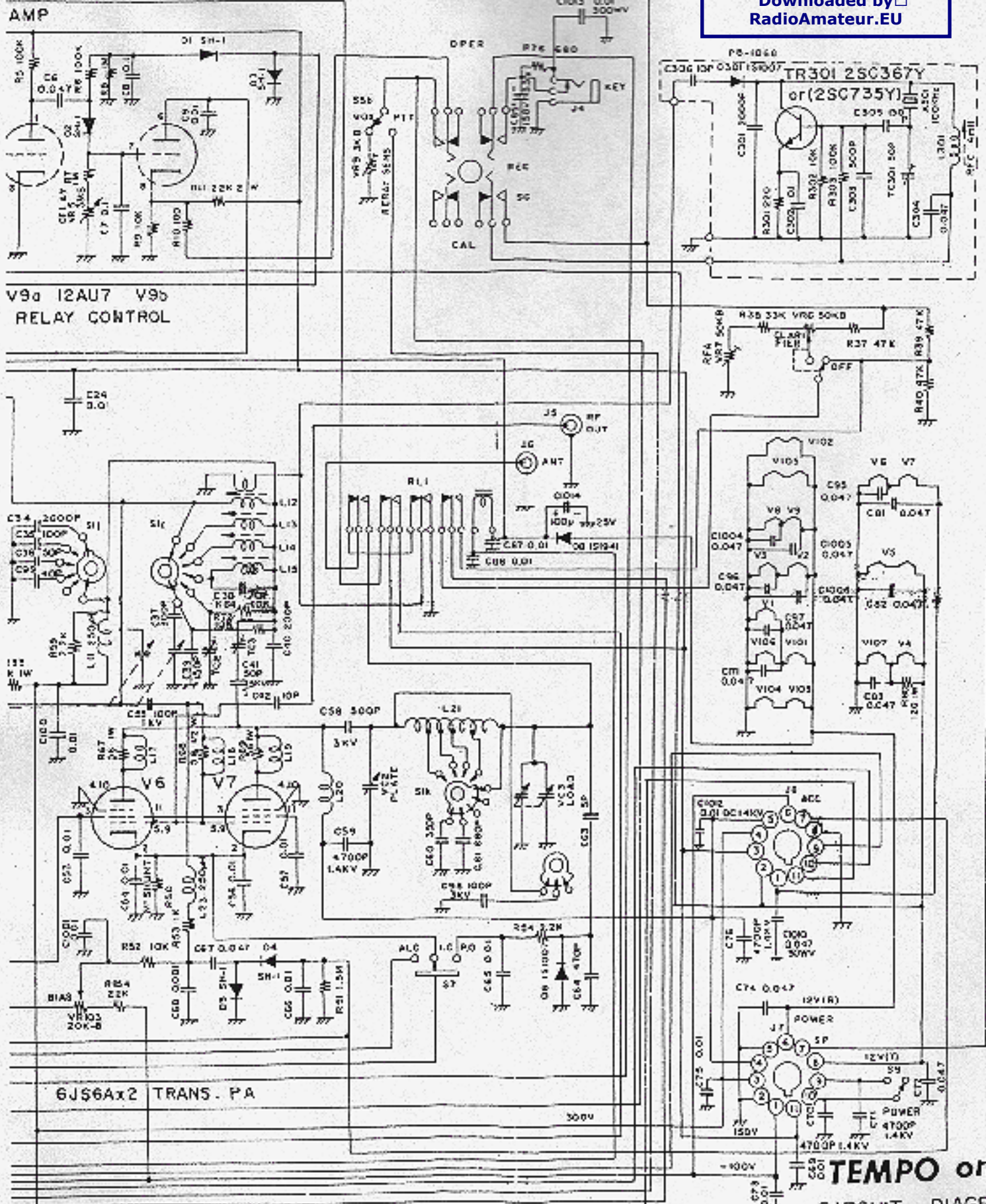

D1-C3
D101-D103 } SH-16/131541
D106

NOTES:

- 1. ALL RESISTORS IN OHM 1/2W ± 10% UNLESS OTHERWISE NOTED.
- 2. ALL CAPACITORS IN µF UNLESS OTHERWISE NOTED.
- 3. X VALUE IS NOMINAL.

TEMPO one
CIRCUIT DIAGRAM
319001