

PRICE \$2.00

# HEATHKIT® ASSEMBLY MANUAL

HEATH COMPANY • BENTON, ARIZONA



## BASIC AMATEUR BAND RECEIVER MODEL HR-10B

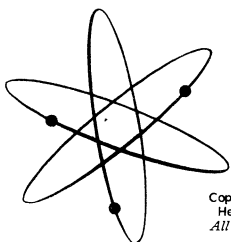





Copyright © 1967  
Heath Company  
All rights reserved

595-945-01  
1-9-70

## TYPICAL COMPONENT TYPES

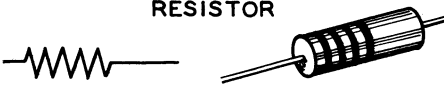
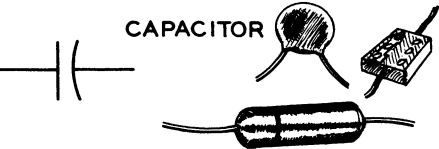
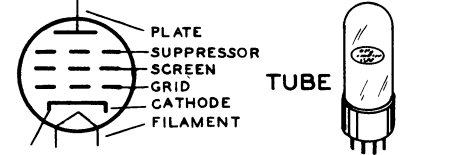
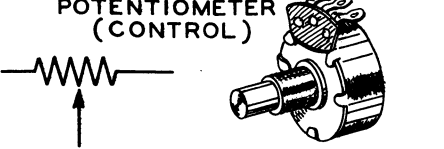
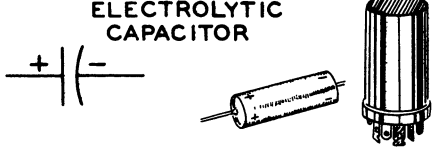
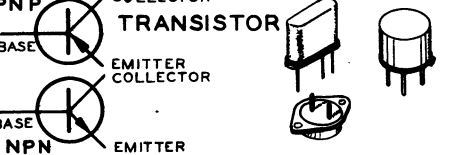
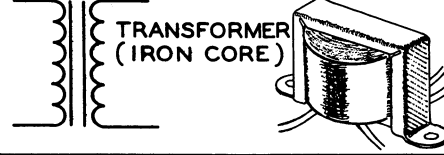
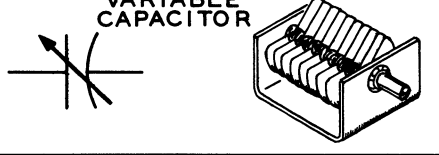
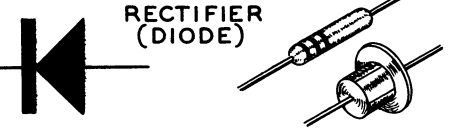
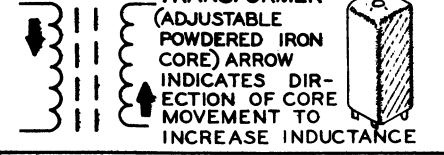
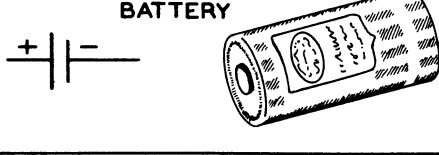
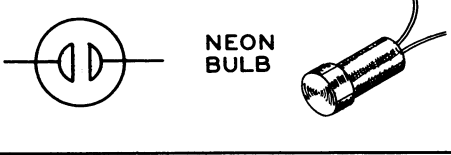
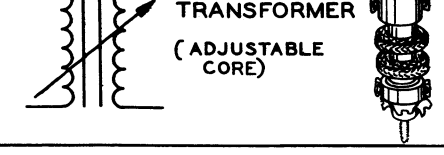
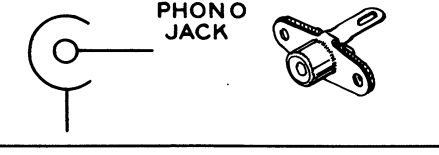
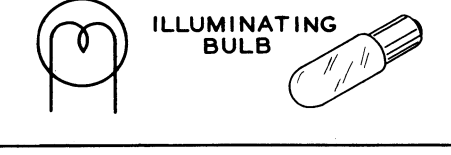
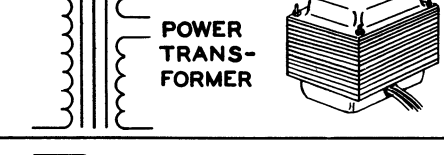
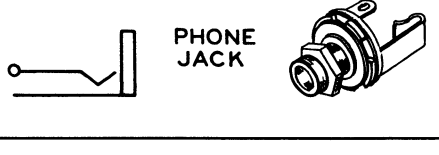
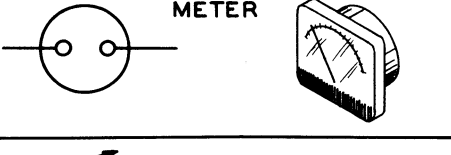
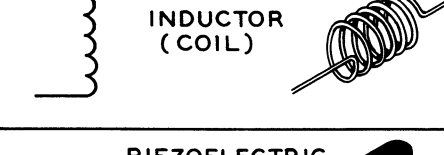
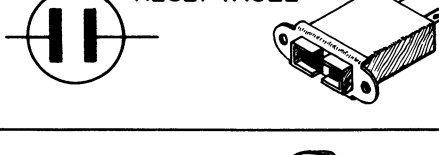
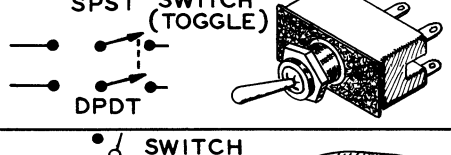
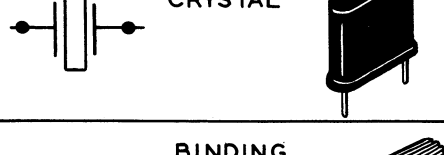
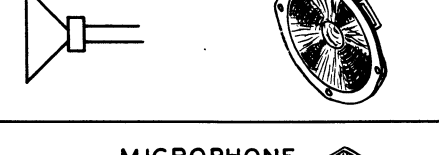
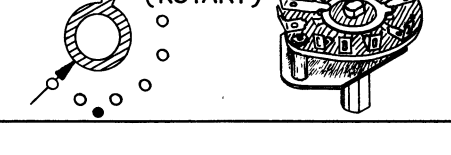
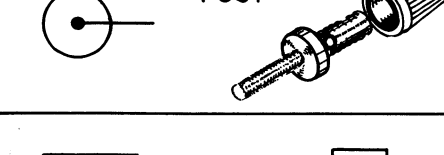
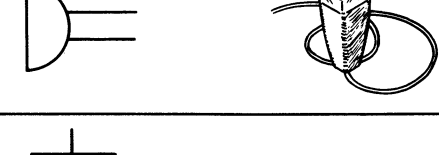
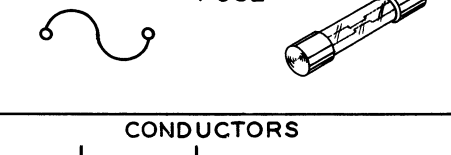
This chart is a guide to commonly used types of electronic components. The symbols and related illustrations

should prove helpful in identifying most parts and reading the schematic diagrams.

<p style="text-align: center;"><b>RESISTOR</b></p> 	<p style="text-align: center;"><b>CAPACITOR</b></p> 	<p style="text-align: center;"><b>TUBE</b></p> 
<p style="text-align: center;"><b>POTENTIOMETER (CONTROL)</b></p> 	<p style="text-align: center;"><b>ELECTROLYTIC CAPACITOR</b></p> 	<p style="text-align: center;"><b>TRANSISTOR</b></p> 
<p style="text-align: center;"><b>TRANSFORMER (IRON CORE)</b></p> 	<p style="text-align: center;"><b>VARIABLE CAPACITOR</b></p> 	<p style="text-align: center;"><b>RECTIFIER (DIODE)</b></p> 
<p style="text-align: center;"><b>TRANSFORMER (ADJUSTABLE POWDERED IRON CORE) ARROW INDICATES DIRECTION OF CORE MOVEMENT TO INCREASE INDUCTANCE</b></p> 	<p style="text-align: center;"><b>BATTERY</b></p> 	<p style="text-align: center;"><b>NEON BULB</b></p> 
<p style="text-align: center;"><b>TRANSFORMER (ADJUSTABLE CORE)</b></p> 	<p style="text-align: center;"><b>PHONO JACK</b></p> 	<p style="text-align: center;"><b>ILLUMINATING BULB</b></p> 
<p style="text-align: center;"><b>POWER TRANSFORMER</b></p> 	<p style="text-align: center;"><b>PHONE JACK</b></p> 	<p style="text-align: center;"><b>METER</b></p> 
<p style="text-align: center;"><b>INDUCTOR (COIL)</b></p> 	<p style="text-align: center;"><b>RECEPTACLE</b></p> 	<p style="text-align: center;"><b>SPST SWITCH (TOGGLE)</b> <b>DPDT</b></p> 
<p style="text-align: center;"><b>PIEZOELECTRIC CRYSTAL</b></p> 	<p style="text-align: center;"><b>SPEAKER</b></p> 	<p style="text-align: center;"><b>SWITCH (ROTARY)</b></p> 
<p style="text-align: center;"><b>BINDING POST</b></p> 	<p style="text-align: center;"><b>MICROPHONE</b></p> 	<p style="text-align: center;"><b>FUSE</b></p> 
<p style="text-align: center;"><b>ANTENNA</b></p> <p style="text-align: center;">GENERAL      LOOP</p> 	<p style="text-align: center;"><b>EARTH GROUND</b></p> <p style="text-align: center;"><b>CHASSIS GROUND</b></p> 	<p style="text-align: center;"><b>CONDUCTORS</b></p> <p style="text-align: center;">NOT CONNECTED      CONNECTED      SHIELDED</p> 

Assembly  
and  
Operation  
of the



# BASIC AMATEUR BAND RECEIVER

MODEL HR-10B

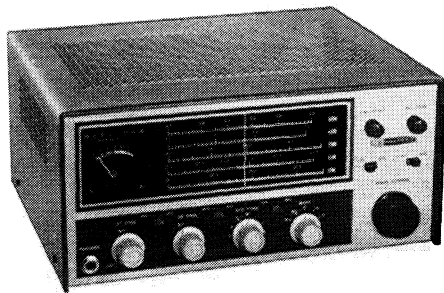

HEATH COMPANY  
BENTON HARBOR,  
MICHIGAN 49022

## TABLE OF CONTENTS

Specifications. . . . .	2
Introduction. . . . .	3
Circuit Description. . . . .	3
Construction Notes. . . . .	4
Parts List. . . . .	5
Proper Soldering Techniques. . . . .	9
Step-By-Step Procedure. . . . .	10
Step-By-Step Assembly. . . . .	11
Parts Mounting. . . . .	11
Transformer Wiring. . . . .	16
Harness Wiring. . . . .	17
Initial Wiring. . . . .	18
Component Installation. . . . .	20
Front End Mounting. . . . .	25
Chassis Top Parts Mounting And Wiring. . . . .	27
Initial Test. . . . .	29
Alignment. . . . .	30
Front End Alignment Chart. . . . .	32
Final Assembly. . . . .	33
Installation And Operation. . . . .	33
Antenna. . . . .	34
In Case Of Difficulty. . . . .	34
Specific Problems. . . . .	35
Factory Repair Service . . . . .	36
Replacement Parts Price List . . . . .	37
Replacement Parts For The Preassembled Front End. . . . .	39
Schematic. . (fold-out from Page) . . . . .	39

The Heath Company reserves the right to discontinue instruments and to change specifications at any time without incurring any obligation to incorporate new features in instruments previously sold.

## SPECIFICATIONS

### Frequency Coverage-

80 Meter Band. . . . .	3.5 to 4.0 mc.
40 Meter Band. . . . .	7.0 to 7.3 mc.
20 Meter Band. . . . .	14.0 to 14.35 mc.
15 Meter Band. . . . .	21.0 to 21.5 mc.
10 Meter Band. . . . .	28.0 to 29.7 mc.
Intermediate Frequency (IF). . . . .	1681.0 kc.
Sensitivity. . . . .	1 microvolt for a 10 db signal plus noise-to-noise ratio.
Selectivity . . . . .	3 kc at 6 db down, 9 kc at 40 db down.
Image Rejection. . . . .	40 db or better.
Input Impedance. . . . .	50 to 75 $\Omega$ , coaxial.
Audio Output Impedance . . . . .	8 $\Omega$ , or 500 $\Omega$ .
Panel Controls. . . . .	AF GAIN, AC OFF-ON. RF GAIN. BFO TUNE. BAND Switch. MAIN TUNING. CALibrate. ANTenna TRIMmer. REC-STBY Switch. CALibrate ON-OFF. BFO On-OFF. AVC On-OFF. ANL On-OFF.
Tube Complement. . . . .	6BZ6 RF Amplifier. 6EA8 Mixer Oscillator. 6BA6 1st IF Amplifier. 6EA8 2nd IF Amplifier-BFO. 6BJ7 Detector-AVC-ANL. 6EB8 1st Audio-Audio output. 6X4 Rectifier.
Power Requirements. . . . .	105-125 or 210-250 volts AC, 50/60 cps, 50 watts.
Cabinet Size. . . . .	13-3/4" wide x 11-1/2" deep x 6-1/2" high.
Net Weight. . . . .	18 lbs.

## INTRODUCTION

Your HEATHKIT Model HR-10B Basic Amateur Band Receiver is designed for use as a high-performance economical station receiver. Frequency coverage of the Receiver includes the amateur bands, 80 through 10 meters, only. Each band is separately calibrated on a large easy-to-read slide-rule dial. The dial is illuminated and provides approximately 6 inches of band-spread for each band.

The Receiver features a signal strength "S" meter, a front panel dial calibration control that operates in conjunction with the 100 kc crystal calibrator provisions, a tuned RF ampli-

fier stage, a crystal filter, an automatic noise limiter circuit, plus many other features desirable on an Amateur Receiver. The low-silhouette styling and the green-gray color combination will prove an attractive addition to any surroundings.

Refer to the "Kit Builders Guide" for complete information on unpacking, parts identification, tools, wiring, soldering, and step-by-step assembly procedures.

## CIRCUIT DESCRIPTION

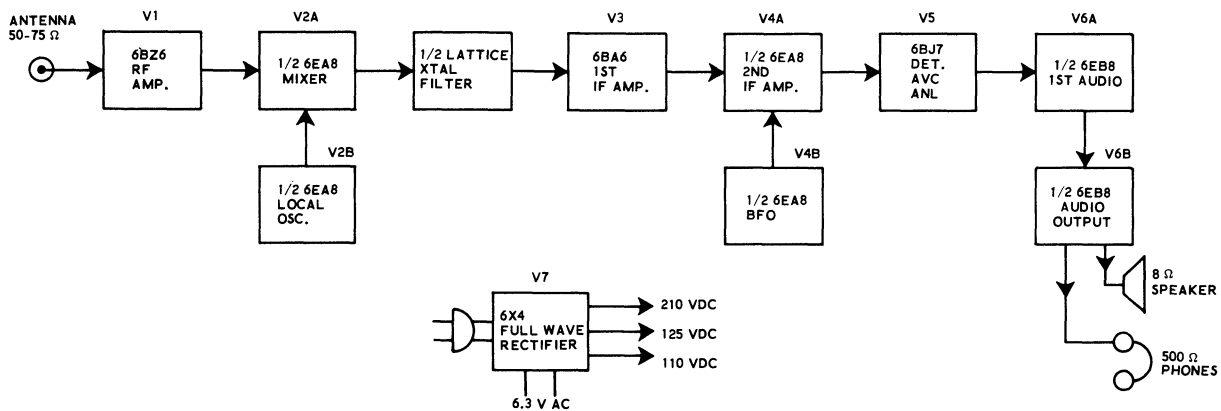

To assist you in understanding the following Circuit Description, we suggest that you refer frequently to the Schematic and Block Diagrams. As the BAND switch is quite complex, the circuit will be discussed with the switch in the 80 meter position.

### RF AMPLIFIER - MIXER OSCILLATOR

Assuming that the BAND switch is in the 80 meter position, the signal from the antenna is applied through coil L1, through the BAND switch, and through capacitor C7 and resistor R1 to the grid of the RF amplifier tube, V1.

V1 amplifies the RF signal which is then applied through capacitor C18 and resistor R10 to the grid in the pentode section of tube V2. Tube V2 is a combination mixer and oscillator.

This tube heterodynes or mixes the incoming signal frequency with the oscillator frequency to obtain a difference frequency of 1681 kc. The position of the BAND switch determines which

coils and capacitors are used in conjunction with V2B in the oscillator circuit. These coils and capacitors, including the MAIN TUNING capacitor, are used to set the oscillator frequency 1681 kc higher than the desired radio station frequency. The difference frequency of 1681 kc is called the intermediate frequency or IF signal.

When the Receiver is used on 10 and 15 meters, the oscillator operates at 1/2 the incoming frequency plus the intermediate frequency. The difference frequency, or IF, is obtained by beating the second harmonic of the oscillator frequency against the incoming signal.

### IF AMPLIFIER

From the plate of V2A, the signal is coupled through IF transformer T1 to the grid of the first IF amplifier tube, V3.

A crystal filter is used in the secondary circuit of the IF transformer to provide a narrow bandpass for suppression of unwanted adjacent signals. This provides the Receiver

with exceptionally good selectivity.

Amplified IF signal from the plate of V3 is coupled through second IF transformer T2 to the grid of IF amplifier tube V4A. Tube V4A again amplifies the IF signal. At this point in the circuit the Beat Frequency Oscillator (BFO) signal from V4B may be beat with the IF signal by turning the BFO switch to BFO. The introduction of the BFO signal produces an audible signal for Continuous Wave (CW) or Single Sideband (SSB) reception. The output from V4A is coupled through IF transformer T3 to tube V5.

### DETECTOR-AUDIO OUTPUT

Tube V5 is the detector stage. This tube detects the audio signal from the IF signal. This

audio signal is then coupled through capacitor C35 and the AF GAIN control to the grid of the first audio stage V6A. The amount of audio signal applied to the grid of V6A can be regulated by the AF GAIN control. This in turn regulates the amount of audio signal that will be amplified by V6A. From tube V6A, the audio signal is coupled by capacitor C38 to the grid of tube V6B. Tube V6B further amplifies this audio signal and feeds it through audio output transformer T4 to the Speaker jack.

### POWER SUPPLY

The power supply uses tube V7 as a full-wave rectifier with power transformer T6. Filtering of the DC voltage is provided by resistors R44 and R43, and capacitors C55, C56, and C57.

## CONSTRUCTION NOTES

This manual is supplied to assist you in every way to complete your kit with the least possible chance for error. The arrangement shown is the result of extensive experimentation and trial. If followed carefully, the result will be highly stable and dependable performance. We suggest that you retain the manual in your files for future reference, both in the use of the equipment and for its maintenance.

**UNPACK THE KIT CAREFULLY AND CHECK EACH PART AGAINST THE PARTS LIST.** In so doing, you will become acquainted with the parts. Refer to the information on the inside covers of the manual to help you identify the components. If some shortage or parts damage is found in checking the Parts List, please read the Replacements section and supply the information called for therein.

Most kit builders find it helpful to separate the various parts into convenient categories. Muffin tins or molded egg cartons make convenient trays for small parts. Resistors and capacitors may be placed with their lead ends inserted in the edge of a piece of corrugated cardboard until they are needed. Values can be written on the cardboard next to each component. The illustration shows one method that may be used.

Resistors generally have a tolerance rating of 10% unless otherwise stated in the Parts List. Tolerances on capacitors are generally even greater. Limits of +100% and -20% are common for electrolytic capacitors.

We suggest that you do the following before work is started:

1. Lay out all parts so that they are readily available.
2. Provide yourself with good quality tools. Basic tool requirements consist of a screwdriver with a 1/4" blade; a small screwdriver with a 1/8" blade; long-nose pliers; wire cutters, preferably separate diagonal cutters; a penknife or a tool for stripping insulation from wires; a soldering iron (or gun) and rosin core solder. A set of nut drivers and a nut starter, while not necessary, will aid extensively in construction of the kit.

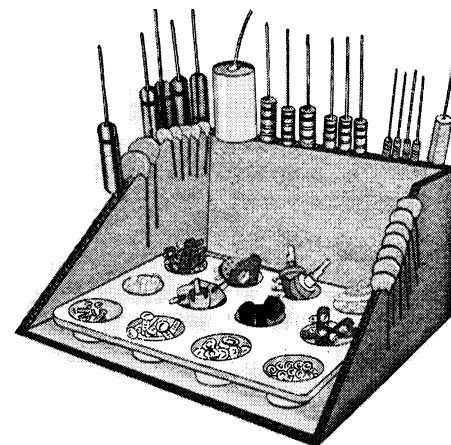

## PARTS LIST

The circled numbers in the Parts List are keyed to the circled numbers on the parts drawings to aid in parts identification.

To order replacement parts, refer to the Replacement Parts Price List and use the Parts Order Form furnished with this kit.

<u>PART No.</u>	<u>PARTS Per Kit</u>	<u>DESCRIPTION</u>
<u>Resistors</u>		
① 1-41	1	10 $\Omega$ 1/2 watt (brown-black-black)
1-3	2	100 $\Omega$ 1/2 watt (brown-black-brown)
1-66	1	150 $\Omega$ 1/2 watt (brown-green-brown)
1-6	2	470 $\Omega$ 1/2 watt (yellow-violet-brown)
1-9	2	1000 $\Omega$ 1/2 watt (brown-black-red)
1-44	2	2200 $\Omega$ 1/2 watt (red-red-red)
1-46	1	3900 $\Omega$ 1/2 watt (orange-white-red)
1-19	1	6800 $\Omega$ 1/2 watt (blue-gray-red)
1-20	2	10 K $\Omega$ 1/2 watt (brown-black-orange)
1-22	1	22 K $\Omega$ 1/2 watt (red-red-orange)
1-25	4	47 K $\Omega$ 1/2 watt (yellow-violet-orange)
1-60	1	68 K $\Omega$ 1/2 watt (blue-gray-orange)
1-26	5	100 K $\Omega$ 1/2 watt (brown-black-yellow)
1-121	3	120 K $\Omega$ 1/2 watt (brown-red-yellow)
1-30	1	270 K $\Omega$ 1/2 watt (red-violet-yellow)
1-34	1	680 K $\Omega$ 1/2 watt (blue-gray-yellow)
1-68	1	820 K $\Omega$ 1/2 watt (gray-red-yellow)
1-35	3	1 megohm 1/2 watt (brown-black-green)
1-37	1	2.2 megohm 1/2 watt (red-red-green)

<u>PART No.</u>	<u>PARTS Per Kit</u>	<u>DESCRIPTION</u>
<u>Resistors (Cont'd.)</u>		
② 1-5-1	1	22 K $\Omega$ 1 watt (red-red-orange)
③ 1-14-2	1	1500 $\Omega$ 2 watt (brown-green-red)
④ 3-11-10	1	1500 $\Omega$ 10 watt wire-wound

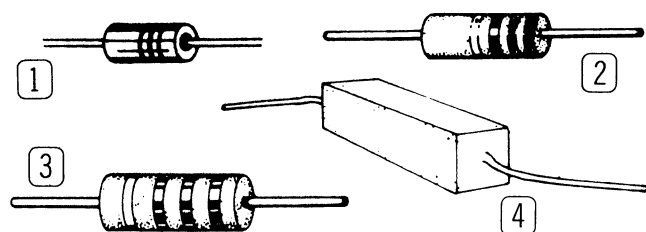

<u>Capacitors</u>		
⑤ 20-100	3	30 $\mu\mu\text{f}$ resin dipped
⑥ 21-3	1	10 $\mu\mu\text{f}$ disc ceramic
21-33	1	3.3 $\mu\mu\text{f}$ disc ceramic
21-22	3	220 $\mu\mu\text{f}$ disc ceramic
21-48	2	.05 $\mu\text{fd}$ disc ceramic
21-81	2	.1 $\mu\text{fd}$ disc ceramic
21-27	23	.005 $\mu\text{fd}$ disc ceramic
21-72	3	.005 $\mu\text{fd}$ 1.4 KV disc ceramic
⑦ 25-4	1	10 $\mu\text{fd}$ 25 V electrolytic
⑧ 25-9	1	20-20-20 $\mu\text{fd}$ 300 V twist-prong electrolytic
26-84	1	15-15-15 $\mu\mu\text{f}$ 3-gang variable
26-64	3	21 $\mu\mu\text{f}$ single-section variable

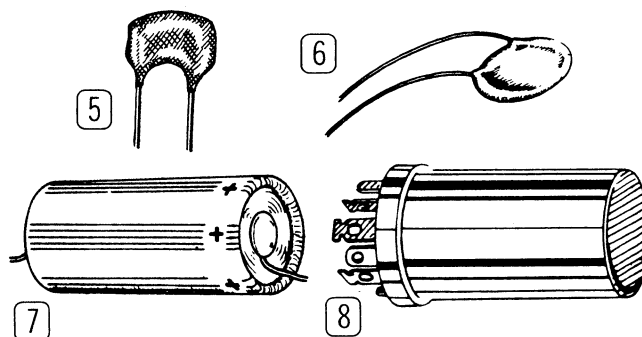

PART No.	PARTS Per Kit	DESCRIPTION
----------	---------------	-------------

PART No.	PARTS Per Kit	DESCRIPTION
----------	---------------	-------------

Coil-Transformers-Choke

① 40-429	1	1682 kc BFO coil
② 45-43	1	Parasitic choke wound on 47 Ω resistor
51-84	1	Audio output transformer
③ 52-17	2	Interstage IF transformer
52-50	1	Input IF transformer
54-122-24	1	Power transformer

Terminal Strips-Sockets-Jack-Plugs

⑨ 431-10	1	3-lug terminal strip
⑩ 431-12	1	4-lug terminal strip
⑪ 431-15	1	1-lug terminal strip
431-16	2	2-lug terminal strip
⑫ 431-45	1	6-lug terminal strip
⑬ 431-40	2	4-lug terminal strip
⑭ 434-34	2	7-pin phenolic tube socket
⑮ 434-35	1	7-pin ceramic tube socket
434-36	1	9-pin ceramic tube socket
⑯ 434-39	2	Octal socket
⑰ 434-42	2	Phono socket
⑱ 434-43	1	9-pin molded tube socket
434-56	2	9-pin phenolic tube socket

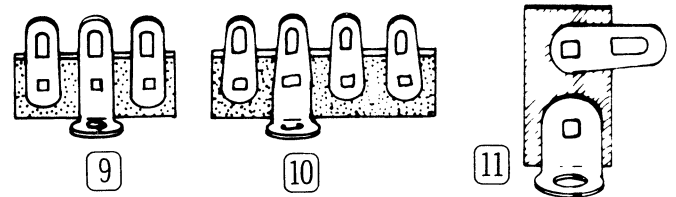
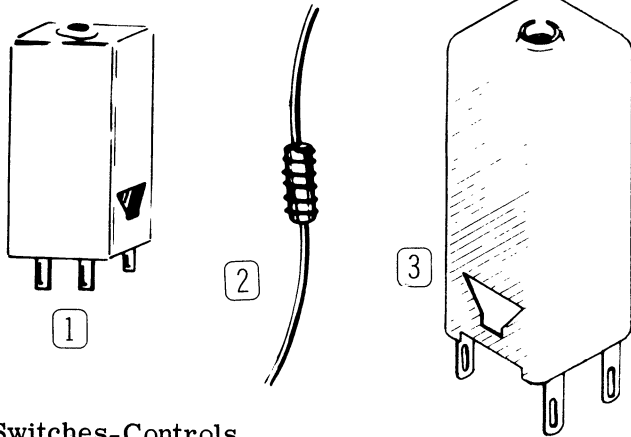

Switches-Controls

④ 10-57	1	10 KΩ tab-mount control
⑤ 10-131	1	10 KΩ control
⑥ 19-72	1	500 KΩ control w/SPST switch
⑦ 60-18	4	SPST slide switch
⑧ 60-36	1	DPDT slide switch

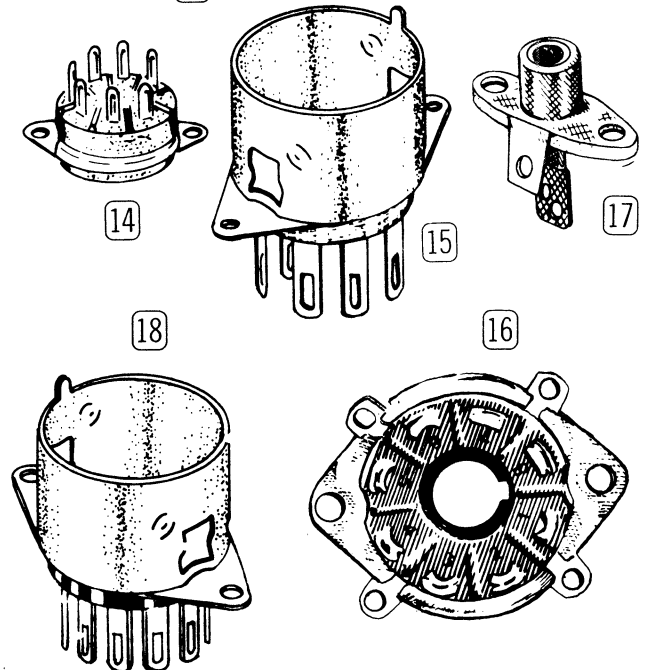
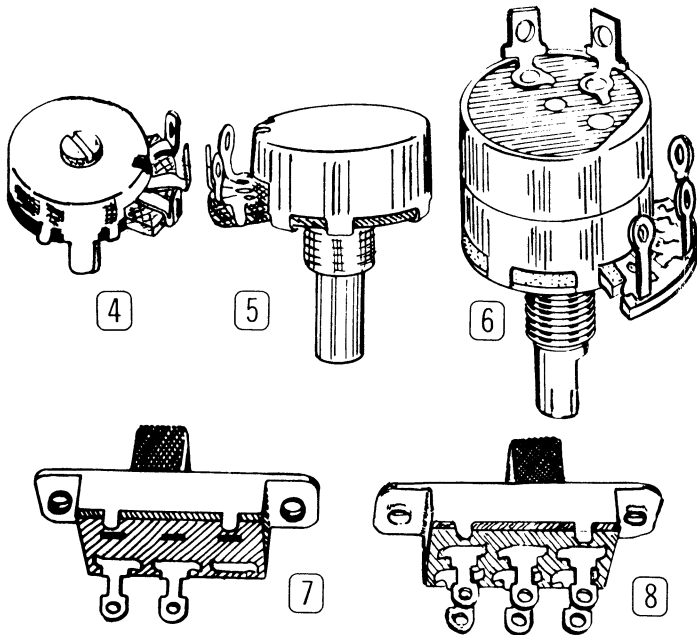
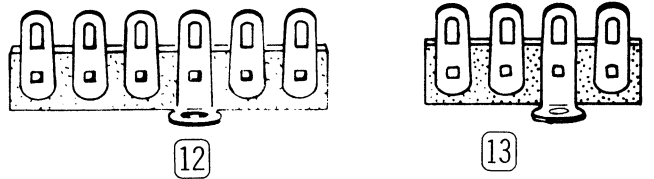



PART No.	PARTS Per Kit	DESCRIPTION
----------	---------------	-------------

Terminal Strips-Sockets-Jack-Plugs (cont'd.)

① 434-74	2	Crystal socket
② 434-85	2	Pilot lamp socket
③ 436-21	1	Phone jack
④ 438-6	1	Octal plug
438-4	2	Phono plug
⑤ 440-1	1	Octal plug cap

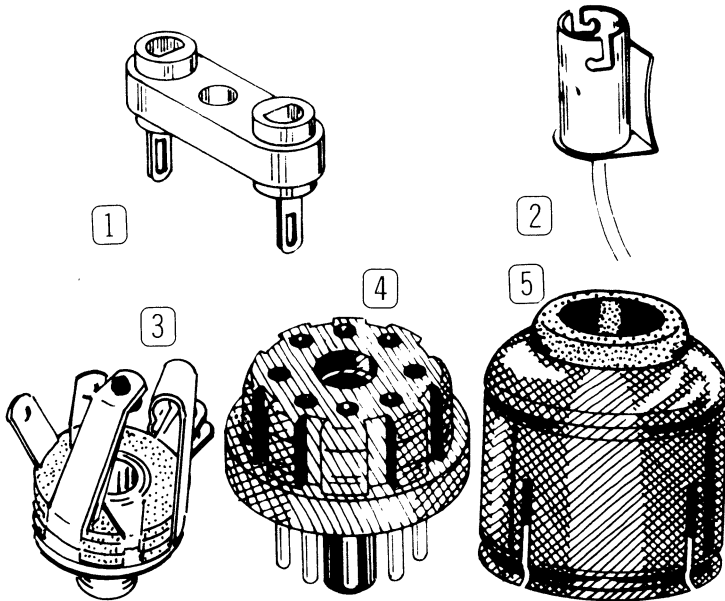

Hardware

⑥ 250-4	2	4-40 x 3/8" round head machine screw
⑦ 250-8	10	#6 x 3/8" sheet metal screw
⑧ 250-18	4	8-32 x 3/8" round head machine screw
⑨ 250-43	1	8-32 x 1/4" setscrew
⑩ 250-49	14	3-48 x 1/4" screw
⑪ 250-56	29	6-32 x 1/4" screw
250-70	3	6-32 x 3/16" flat head screw
⑫ 250-89	7	6-32 x 3/8" screw
⑬ 250-100	3	6-32 x 5/16" setscrew
⑭ 250-116	6	6-32 x 1/4" truss head machine screw (black)
⑮ 250-138	9	6-32 x 3/16" screw

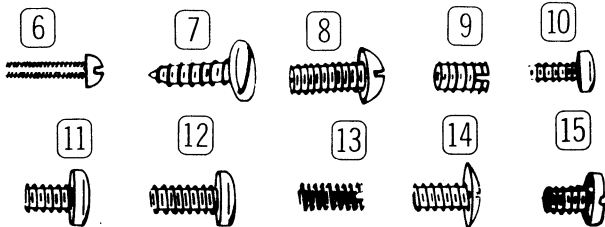

PART No.	PARTS Per Kit	DESCRIPTION
----------	---------------	-------------

Hardware (cont'd.)

⑯ 252-1	14	3-48 nut
⑰ 252-3	50	6-32 nut
⑱ 252-4	4	8-32 nut
⑲ 252-7	4	Control nut
⑳ 252-15	12	4-40 nut
㉑ 252-22	4	6-32 speednut
㉒ 253-9	4	#8 flat steel washer
㉓ 253-10	4	Control flat washer
㉔ 253-36	2	Formed spring brass washer
㉕ 253-49	1	Flat nylon washer
㉖ 254-1	64	#6 lockwasher
㉗ 254-2	4	#8 lockwasher
㉘ 254-4	4	Control lockwasher
㉙ 254-7	20	#3 lockwasher
㉚ 254-9	12	#4 lockwasher

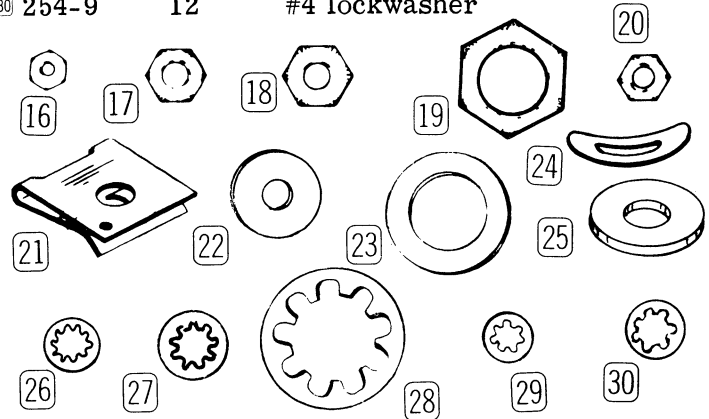

⑳ 255-30	1	Spacer
㉑ 258-1	1	Dial cord spring
㉒ 259-1	4	#6 solder lug
㉓ 259-6	5	#6 small solder lug
㉔ 259-10	1	Control solder lug
㉕ 260-7	4	IF transformer clip
㉖ 260-29	2	Crystal holding clip

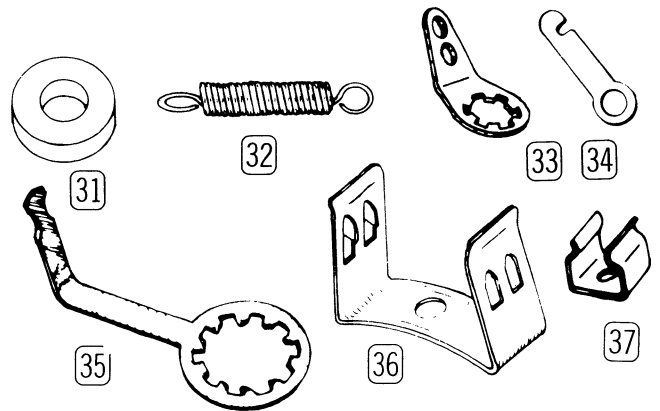

PART No.	PARTS Per Kit	DESCRIPTION
<u>Grommets-Wire</u>		
① 73-1	2	3/8" rubber grommet
② 73-4	4	5/16" rubber grommet
89-1	1	Line cord with plug
134-40	1	Wiring harness
206-4	1	Length spiral shield
340-8	1	Length #22 bare wire
343-2	1	Length coax cable
344-51	1	Length brown hookup wire
344-52	1	Length red hookup wire
344-54	1	Length yellow hookup wire
346-4	1	Length sleeving 1/16" diameter
346-2	1	Length sleeving 3/16" diameter



<u>Tubes-Crystals-Pilot Lamps -Fuse</u>		
404-184	1	1680.70 kc ±.005% tolerance crystal
404-185	1	1682.40 kc ± .005% tolerance crystal
407-90	1	Meter
411-64	1	6X4 tube
411-90	1	6BA6 tube
411-113	1	6BJ7 tube
411-124	2	6EA8 tube
411-126	1	6BZ6 tube
411-161	1	6EB8 tube
412-20	2	#47 pilot lamp
421-20	1	1/2 ampere slow-blow fuse

<u>Shafts-Flywheel-Bushings-Knobs</u>		
453-35	1	1/4" diameter x 4-3/8" long shaft
453-90	1	1/4" x 1-7/8" shaft
453-114	1	1/4" x 2-1/2" dial cord drive shaft
454-12	1	Flywheel
③ 455-9	1	3/8" x 3/8" bushing
455-15	1	1/4" x 1/4" collar
④ 456-7	2	Metal coupling
462-257	1	1-9/16" diameter green knob
462-122	4	Gray knob with skirt and pointer
462-258	2	9/16" diamter green knob with white pointer mark

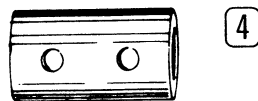
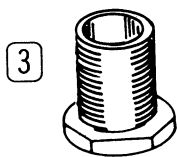

PART No.	PARTS Per Kit	DESCRIPTION
<u>Metal Parts</u>		
90-358	1	Top cover
100-362	1	Dial drum
100-369-1	1	Dial back plate assembly
⑤ 100-370	1	Pulley bracket assembly
100-640	1	Front panel
110-8	1	Front end tuner assembly
200-332-1	1	Chassis
204-449	2	Variable capacitor mounting bracket
⑥ 204-450	1	Pilot lamp bracket
⑦ 204-451	1	Pilot lamp bracket
205-260	1	Chassis bottom plate
⑧ 205-337	2	Dial spacer plate
205-350-1	1	Meter spacer plate

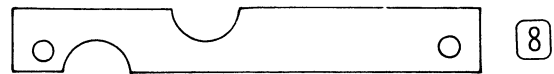
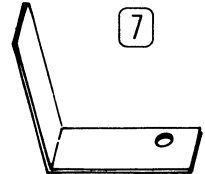
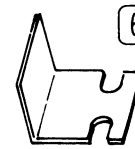
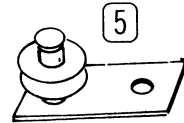

<u>Miscellaneous</u>		
⑨ 75-24	1	Line cord strain relief
206-3	2	9-pin tube shield
206-25	1	7-pin tube shield
261-9	4	Rubber foot
349-3	1	Length dial cord
⑩ 422-1	1	Fuse block
463-31	1	Dial pointer
481-2	1	Capacitor mounting wafer
490-1	1	Alignment tool
490-5	1	Nut starter
464-23-2	1	Dial plate (plastic)
391-34	1	Blue and white identification label
597-260	1	Parts Order Form
597-308	1	Kit Builders Guide
	1	Manual (see front cover for part number)
		Solder

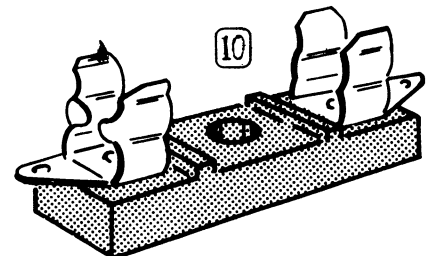

## PROPER SOLDERING TECHNIQUES

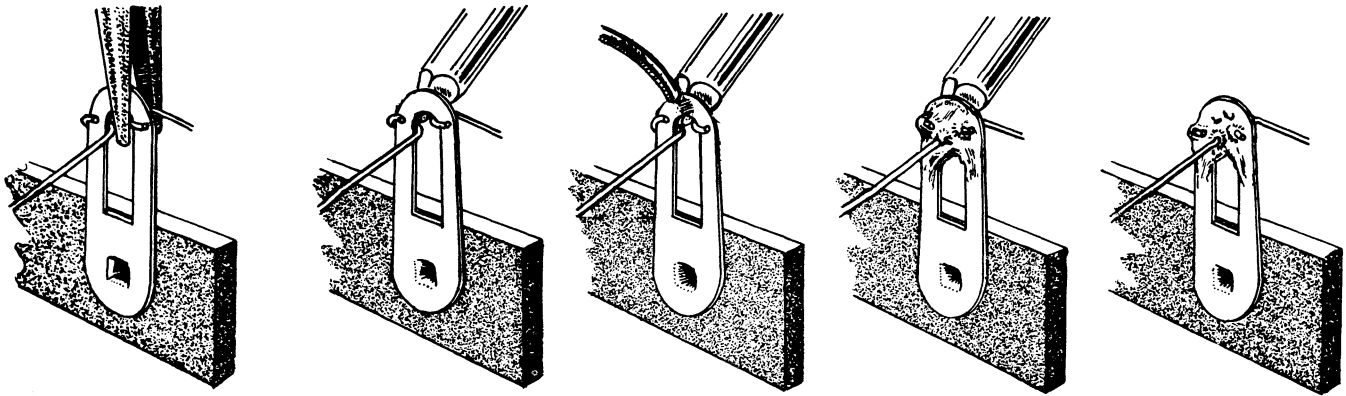

CRIMP WIRES    HEAT CONNECTION    APPLY SOLDER    ALLOW SOLDER TO FLOW    PROPER SOLDER CONNECTION

Only a small percentage of customers find it necessary to return equipment for factory service. By far the largest portion of malfunctions in this equipment are due to poor or improper soldering.

If terminals are bright and clean and free of wax, frayed insulation and other foreign substances, no difficulty will be experienced in soldering. Correctly soldered connections are essential if the performance engineered into a kit is to be fully realized. If you are a beginner with no experience in soldering, a half hour's practice with some odd lengths of wire may be a worthwhile investment.

For most wiring, a 25 to 100 watt iron or its equivalent in a soldering gun is very satisfactory. A lower wattage iron than this may not heat the connection enough to flow the solder smoothly. Keep the iron tip clean by wiping it from time to time with a cloth.

### CHASSIS WIRING AND SOLDERING

1. Unless otherwise indicated, all wire used is the type with colored insulation (hookup wire). In preparing a length of hookup wire, 1/4" of insulation should be removed from each end unless directed otherwise in the assembly step.
2. To avoid breaking internal connections when stripping insulation from the leads of transformers or similar components, care should be taken not to pull directly on the lead. Instead, hold the lead with pliers while it is being stripped.
3. Leads on resistors, capacitors, and similar components are generally much longer than need be to make the required connections. In these cases, the leads should be cut to proper length before the part is installed. In general, the leads should be just long enough to reach their terminating points.
4. Wherever there is a possibility of bare leads shorting to other parts or to the chassis, the leads should be covered with insulating sleeving. Where the use of sleeving is specifically intended, the phrase "use sleeving" is included in the associated assembly step. In any case where there is the possibility of an unintentional short circuit, sleeving should be used. Extra sleeving is provided for this purpose.
5. Crimp or bend the lead (or leads) around the terminal to form a good joint without relying on solder for physical strength. If the lead is too large to allow bending or if the step states that it is not to be crimped, position it so that a good solder connection can still be made.
6. Position the work, if possible, so that gravity will help to keep the solder where you want it.
7. Place a flat side of the soldering iron tip against the joint to be soldered until it is heated sufficiently to melt the solder.
8. Then place the solder and it will immediately flow over the joint; use only enough solder to thoroughly wet the junction. It is usually not

necessary to fill the entire hole in the terminal with solder.

9. Remove the solder and then the iron from the completed joint. Use care not to move the leads until the solder is solidified.

A poor or cold solder joint will usually look crystalline and have a grainy texture, or the solder will stand up in a blob and will not have adhered to the joint. Such joints should be reheated until the solder flows smoothly. In some cases, it may be necessary to add a

little more solder to achieve a smooth, bright appearance.

ROSIN CORE SOLDER HAS BEEN SUPPLIED WITH THIS KIT. THIS TYPE OF SOLDER MUST BE USED FOR ALL SOLDERING IN THIS KIT. ALL GUARANTEES ARE VOIDED AND WE WILL NOT REPAIR OR SERVICE EQUIPMENT IN WHICH ACID CORE SOLDER OR PASTE FLUXES HAVE BEEN USED. IF ADDITIONAL SOLDER IS NEEDED, BE SURE TO PURCHASE ROSIN CORE (60:40 or 50:50 TIN-LEAD CONTENT) RADIO TYPE SOLDER.

## STEP-BY-STEP PROCEDURE

The following instructions are presented in a logical step-by-step sequence to enable you to complete your kit with the least possible confusion. Be sure to read each step all the way through before beginning the specified operation. Also read several steps ahead of the actual step being performed. This will familiarize you with the relationship of the subsequent operations. When the step is completed, check it off in the space provided. This is particularly important as it may prevent errors or omissions, especially if your work is interrupted. Some kit builders have also found it helpful to mark each wire and part in colored pencil on the Pictorial as it is added.

The fold-out diagrams in this manual may be removed and attached to the wall above your working area; but because they are an integral part of the instructions, they should be returned to the manual after the kit is completed.

In general, the illustrations in this manual correspond to the actual configuration of the kit; however, in some instances the illustra-

tions may be slightly distorted to facilitate clearly showing all of the parts.

The abbreviation "NS" indicates that a connection should not be soldered yet as other wires will be added. When the last wire is installed, the terminal should be soldered and the abbreviation "S" is used to indicate this. Note that a number will appear after each solder instruction. This number indicates the number of leads that are supposed to be connected to the terminal in point before it is soldered. For example, if the instruction reads, "Connect a wire to lug 1 (S-2)," it will be understood that there will be two wires connected to the terminal at the time it is soldered. (In cases where a wire passes through a terminal or lug and then connects to another point, it will count as two wires, one entering and one leaving the terminal.)

The steps directing the installation of resistors include color codes to help identify the parts. Also, if a part is identified by a letter-number designation (R1, C1, etc.) on the Schematic, its designation will appear at the beginning of the assembly step which directs its installation.

# STEP-BY-STEP ASSEMBLY

## PARTS MOUNTING

NOTE: Lockwashers will be used with all screws and nuts when mounting parts, unless otherwise stated; the following steps will only call out the size and type of hardware to be used. For parts identification refer to the Parts Pictures which are located on Pages 5 to 8.

Refer to Pictorial 1 (fold-out from Page 15) for the following steps.

- (✓) Referring to Detail 1A, mount a phono socket at locations BA and BF on the rear apron. Use 6-32 x 1/4" hardware.

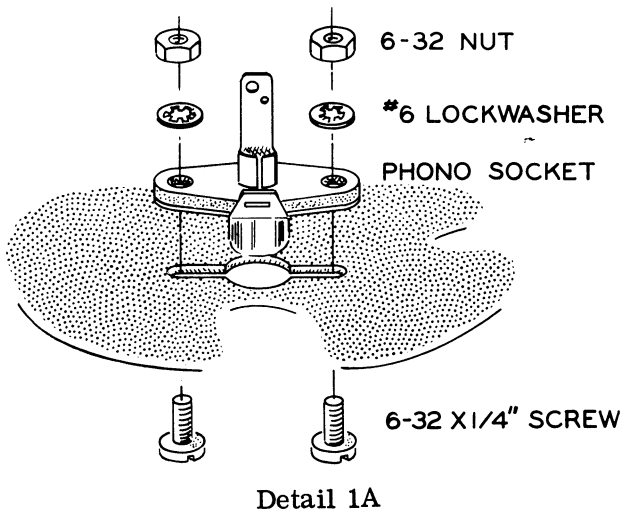

- (✓) Referring to Detail 1B, mount an octal tube socket at location BD and 4-lug terminal strip at BC. Use 6-32 x 3/8" hardware for the double mounting, and use 6-32 x 1/4" hardware for the other mounting. Be sure to place the keyway of the socket as shown in Pictorial 1.

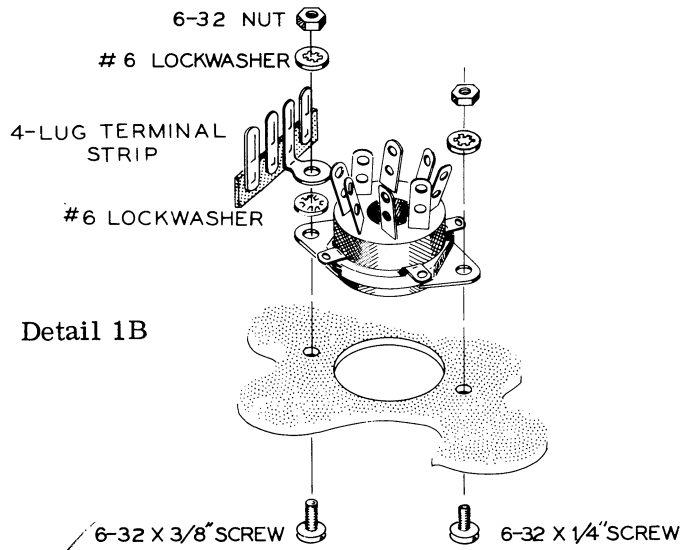

- (✓) R23. Mount the 10 KΩ twist-tab control (#10-57) at location BE on the rear apron. Refer to Detail 1C for the proper procedure. Position the control lugs as shown.

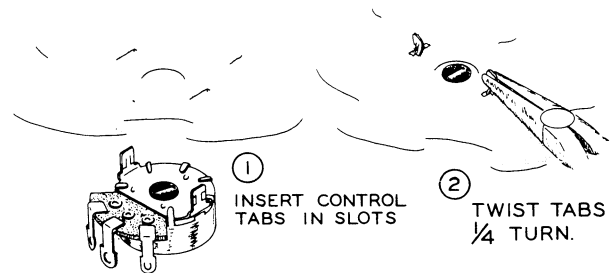

- (✓) Referring to Detail 1D, mount the fuse block at location T. Use 6-32 x 3/8" hardware. Position the fuse block as shown.
- (✓) Mount an octal socket at location CC. Use 6-32 x 1/4" hardware. Position the keyway as shown.

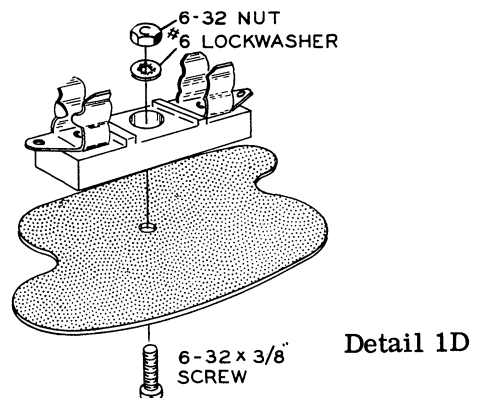

- Referring to Detail 1E, mount the 7-pin ceramic tube socket at location V1 with a #6 small solder lug on one mounting screw. Use 3-48 x 1/4" hardware. Position the blank space of the tube socket as shown in Pictorial 1.

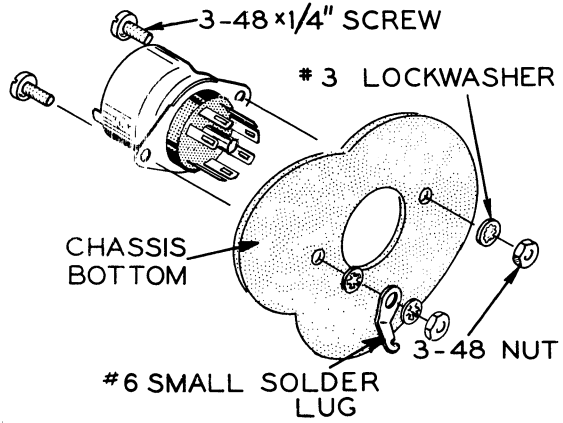

Detail 1E

- Mount the 9-pin ceramic tube socket at location V2 with a #6 small solder lug on one mounting screw. Use 3-48 x 1/4" hardware. Position the blank space as shown.
- Mount a 7-pin phenolic tube socket at location V3 with a #6 small solder lug on one mounting screw. Use 3-48 x 1/4" hardware. Position the blank space as shown.
- Mount a second 7-pin phenolic tube socket at location V7 with a #6 small solder lug on one mounting screw. Use 3-48 x 1/4" hardware. Position the blank space as shown.
- Mount 9-pin phenolic tube sockets at locations V5 and V6. Use 3-48 x 1/4" hardware. Position the blank space as shown.
- Mount the 9-pin molded tube socket on top of the chassis at location V4 with a #6 small solder lug on one mounting screw. Use 3-48 x 1/4" hardware. Position the blank space as shown.
- Referring to Detail 1F, mount a 4-lug terminal strip at location A. Use 6-32 x 1/4" hardware.
- Mount 2-lug terminal strips at locations Q and S. Use 6-32 x 1/4" hardware.

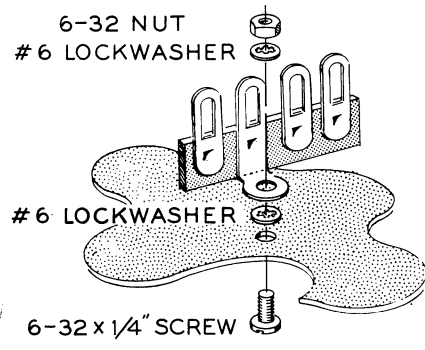

Detail 1F

- Mount a 3-lug terminal strip at location L. Use 6-32 x 1/4" hardware.
- Mount a 6-lug terminal strip at location F. Use 6-32 x 1/4" hardware.
- Mount a 1-lug terminal strip at location G. Use 6-32 x 1/4" hardware.
- Install 3/8" rubber grommets at locations HB and HG.
- Install the remaining grommets at HA, HD, HE, and HF.
- Referring to Detail 1G, mount crystal sockets and crystal clips at locations M and N. Use 4-40 x 3/8" hardware. Do not over-tighten the hardware or you may crack the sockets.

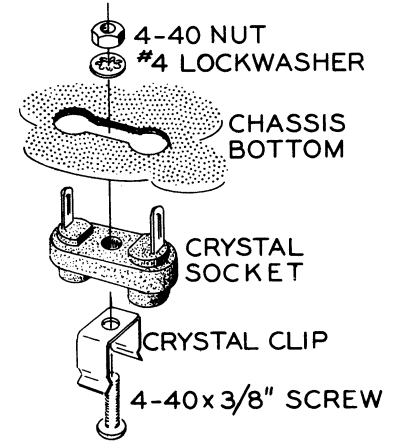

Detail 1G

- Mount #6 solder lugs at locations D, J, and U. Use 6-32 x 1/4" hardware. Position the solder lugs as shown.

- (✓) T2, T3. Referring to Detail 1H, mount inter-stage IF transformers (#52-17) at locations B and K. Use IF transformer mounting clips. Be sure to place the color dots as shown in Pictorial 1.

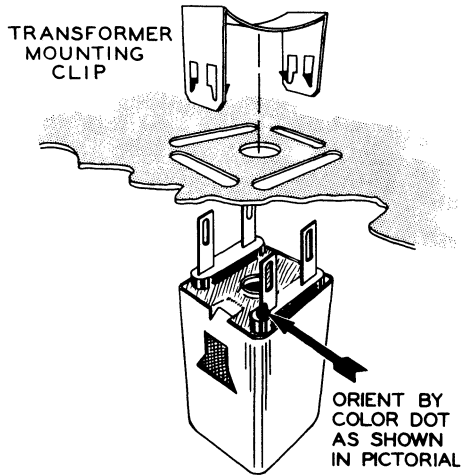

Detail 1H

- (✓) T5. Mount the BFO coil (#40-429) at location C. Use an IF transformer mounting clip. Place the color dot as shown.
- (✓) T1. Similarly, mount the input IF transformer (#52-50) at location P. Use an IF transformer mounting clip. Place the color dot as shown.
- (✓) Referring to Detail 1J, mount the electrolytic capacitor mounting wafer at location H. Use 6-32 x 1/4" hardware. Position the mounting lug slots as shown.
- (✓) C55, C56, C57. Again refer to Detail 1J and mount the electrolytic capacitor at H. Position the capacitor lug markings as shown in Pictorial 1. Secure the capacitor by twisting each mounting lug 1/4 turn with long-nose pliers.

Cut the power transformer leads as follows:

LEAD COLOR	LENGTH
(✓) Red	4-1/2"
(✓) Red	3"
(✓) Green	3-3/4"
(✓) Green	3-1/2"
(✓) Black	11"
(✓) Black-green	11"
(✓) Black-yellow	5-1/4"
(✓) Black-red	5-1/4"
(✓) Red-yellow	3-3/4"

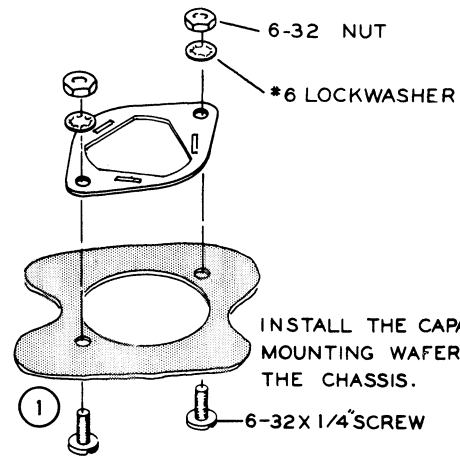

INSTALL THE CAPACITOR MOUNTING WAFER ON THE CHASSIS.

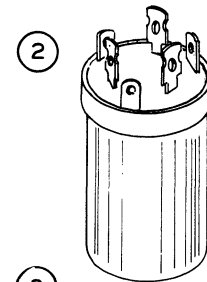

POSITION THE CAPACITOR AS SHOWN IN PICTORIAL 1, THEN PUSH THE CAPACITOR INTO THE WAFER.



WHILE HOLDING THE CAPACITOR IN PLACE, TWIST EACH OF ITS MOUNTING LUGS APPROXIMATELY 1/4 TURN.

Detail 1J

- (✓) Strip 1/4" of insulation from the end of each lead.

Cut the audio output transformer leads as follows:

LEAD COLOR	LENGTH
(✓) Red	4"
(✓) Blue	3-3/4"
(✓) White	7-1/2"
(✓) Green	7"
(✓) Black	2-3/4"

- (✓) Strip 1/4" of insulation from the end of each transformer lead.

- (✓) T4. Mount the audio output transformer at location E with a 6-32 x 1/4" screw, #6 solder lug, and a 6-32 nut. Secure the other mounting foot with 6-32 x 1/4" hardware. Be sure to place all of the transformer leads through grommet HB.

- ( ) T6. Mount the power transformer with its leads through hole HC. Secure the transformer with 8-32 x 3/8" hardware.
- (✓) Referring to Detail 1K, mount a variable capacitor mounting bracket on top of the chassis at location FN and a 4-lug terminal strip below the chassis at location R. Use 6-32 x 3/8" hardware for the double mounting and 6-32 x 1/4" hardware for the remaining mounting holes.

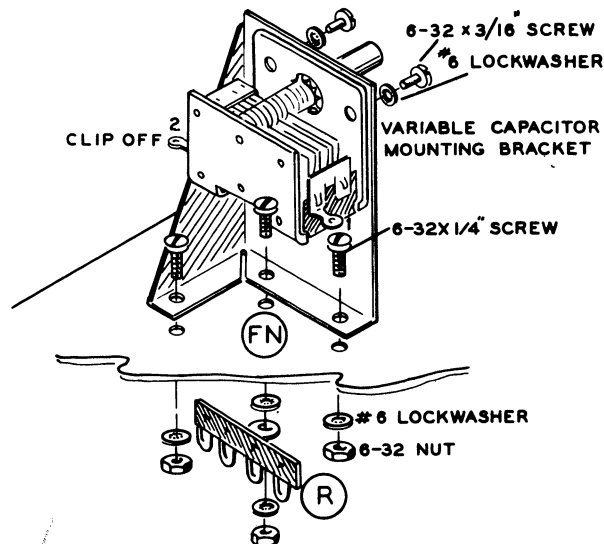

Detail 1K

- (✓) Mount the remaining variable capacitor mounting bracket at location FM on top of the chassis. Use 6-32 x 1/4" hardware.
- (✓) C62. Again referring to Detail 1K, clip off lug 2 of a 21  $\mu\mu\text{f}$  variable capacitor and mount this capacitor on the variable capacitor mounting bracket at location FM. Use #6 lockwashers and 6-32 x 3/16" screws. Turn the capacitor shaft until the plates are fully meshed. This will protect them from being bent.
- (✓) C45. Similarly, clip off lug 2 of another 21  $\mu\mu\text{f}$  variable capacitor and mount this capacitor on the variable capacitor mounting bracket at location FN. Use #6 lockwashers and 6-32 x 3/16" screws. Turn the capacitor shaft until the plates are fully meshed.

- (✓) Mount a SPST slide switch (#60-18) at location FC on the front apron. Use #4 lockwashers and 4-40 nuts. Position the switch lugs as shown.
- (✓) Mount the DPDT slide switch (#60-36) at location FE on the front apron. Use #4 lockwashers and 4-40 nuts.
- (✓) Mount a SPST slide switch at location FG on the front apron. Use #4 lockwashers and 4-40 nuts. Position the switch lugs as shown. Bend the lugs at a 90 degree angle as shown in Pictorial 1.
- (✓) C41. Mount the remaining 21  $\mu\mu\text{f}$  variable capacitor (#26-64) at location FF on the front apron. Use 6-32 x 3/16" flat head screws. Do not use #6 lockwashers.
- (✓) Start a 6-32 x 5/16" setscrew in the dial drum. Place the dial drum on the shaft of the MAIN TUNING capacitor (#26-84).
- (✓) C6A, C6B, C6C. Mount the MAIN TUNING capacitor on the top side of the chassis as shown in Detail 1L. Secure the capacitor with 6-32 x 3/16" screws, and #6 lockwashers.

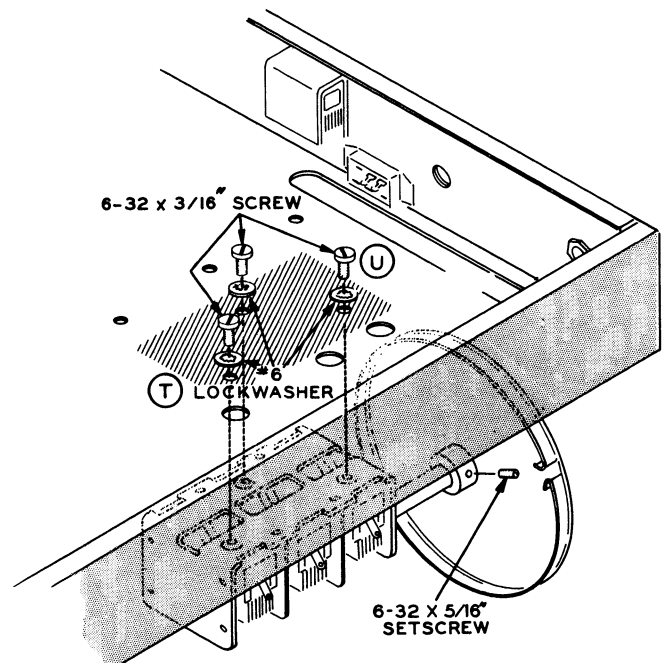

Detail 1L



- ( ) Locate the front panel and referring to Detail 1M (fold-out from this page), mount SPST slide switches at locations FK and FL along with a pilot lamp bracket. Use #4 lockwashers and 4-40 nuts on the studs.
- ( ) Carefully remove the meter from its box. When handling the meter, be careful not to bend the pointer or scratch the meter face.
- ( ) Remove any wire between the meter terminals.
- ( ) Referring to Detail 1N, mount the S meter to the dial back plate. Tilt the meter so that the dial plate can be inserted between the meter pointer and the meter face. Place the meter spacer plate in position. Secure the meter and the meter spacer plate to the dial back plate with the two black 6-32 x 1/4" truss head machine screws and 6-32 nuts.
- ( ) Place the dial pointer on the dial backplate assembly. Place a piece of tape over the rear of the pointer to hold it in place.

- ( ) Locate the plastic dial plate. Handle the plastic by its edges to avoid finger smudges. Remove the protective paper. Using a solution of a few drops of household detergent (Joy, Liquid Lux, etc.,) in a cup of lukewarm water, wipe over both sides of the plastic plate with a sponge or soft cloth. This will prevent static charges from collecting on the plastic that normally attracts dust particles, and will also clean any smudges that may be present.
- ( ) Again, referring to Detail 1N, mount the dial plate so that the lettering can be read from the front panel, the dial spacer plates, dial back plate assembly, pulley bracket assembly, and the pilot lamp bracket to the front panel. Use #6 lockwashers and 6-32 nuts on the front panel studs. Use care when tightening to prevent breaking the studs from the front panel. Also line up the pilot lamp holes in the dial plate, dial spacer plate, and dial backplate.

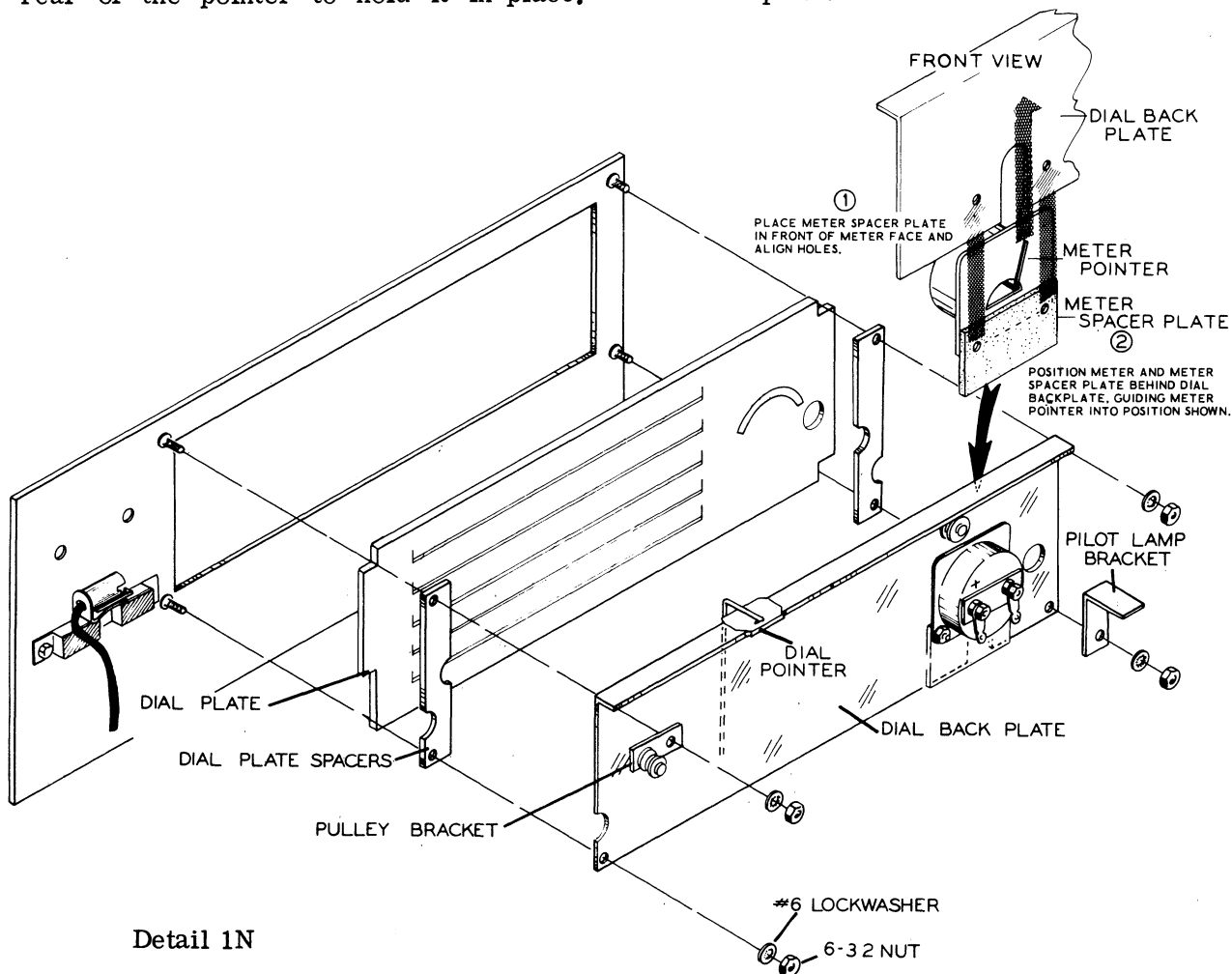

Detail 1N

- ✓ R33. Referring to Detail 1P and Pictorial 1, mount the front panel to the front apron with the AF GAIN control (#19-72) at location FB on the front apron. Use a control solder lug on the control bushing and a control flat washer and control nut on the front panel side. Do not tighten securely yet.

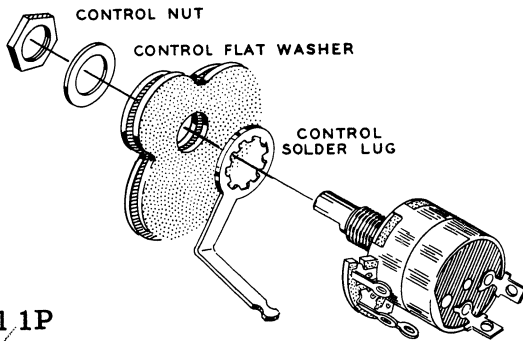

Detail 1P

- ✓ R5. Similarly, mount the RF GAIN control (#10-131) at location FD. Use a large spacer, two control lockwashers, a control flat washer, and a control nut. See Detail 1Q. Do not tighten securely yet.

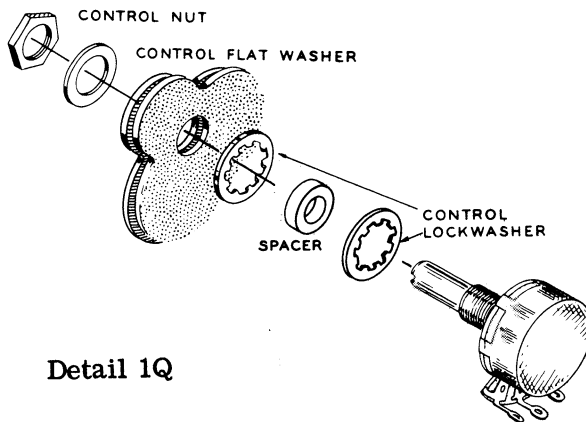

Detail 1Q

- ✓ Mount the phone jack on the front apron at location FA. Use a control lockwasher, control flat washer, and a control nut. Do not tighten securely yet.
- ( ) Mount a 3/8" x 3/8" brass bushing at location FJ on the front apron. Pass this bushing through from the front panel side. Use a control lockwasher, control flat washer, and a control nut. Now tighten all control nuts.
- ✓ Mount a 6-32 speednut in the cutout at each corner of the chassis. Be sure that the flat

side of each speednut faces outward as shown in Pictorial 1.

## TRANSFORMER WIRING

Refer to Pictorial 2 for the following steps.

Connect the audio output transformer leads as follows:

<u>LEAD COLOR</u>	<u>CONNECT TO</u>
✓ Black	solder lug E (NS).
✓ Blue	lug 9 of tube socket V6 (NS).
( ) Red	lug 3 of electrolytic capacitor H (NS).
✓ Green	lug 2 of phone jack FA (S-1).
( ) White	lug 3 of phone jack FA (NS).

Connect the power transformer leads as follows:

<u>LEAD COLOR</u>	<u>CONNECT TO</u>
( ) Short red	lug 1 of tube socket V7 (S-1).
✓ Long red	lug 6 of tube socket V7 (S-1).
( ) Short green	lug 3 of tube socket V7 (NS).
( ) Long green	lug 4 of electrolytic capacitor H (NS).
✓ Red-yellow	lug 4 of electrolytic capacitor H (S-2). Apply enough solder and heat to securely solder the mounting tab to the capacitor mounting wafer.

Two sets of line voltage wiring instructions are given below, one for 120 VAC line voltage and the other for 240 VAC line voltage. In the U.S.A., 120 VAC is most often used, while in foreign countries 240 VAC is more common. **USE ONLY THE INSTRUCTIONS THAT AGREE WITH THE LINE VOLTAGE IN YOUR AREA.**

### 120 VAC Wiring

- ✓ Twist together loosely the black and black-green leads. Then connect both to lug 4 of control FB (S-2).
- ✓ Twist together loosely the black-red and black-yellow leads. Then connect both to lug 2 of terminal strip BC (NS).

Now proceed to Harness Wiring.

**240 VAC Wiring**

Refer to Detail 2A for the following steps.

- ( ) Cut the black-green lead to the same length as the black-yellow lead. Then twist these leads together loosely and connect both to lug 1 of terminal strip BC (S-2).
- ( ) Connect the black lead to lug 4 of control FB (S-1).
- ( ) Connect the black-red lead to lug 2 of terminal strip BC (NS).

**HARNESS WIRING**

NOTE: In the following steps, the harness break-out points will be referred to with the letters BO.

- (✓) Locate the wiring harness and form it as shown in Detail 2B.

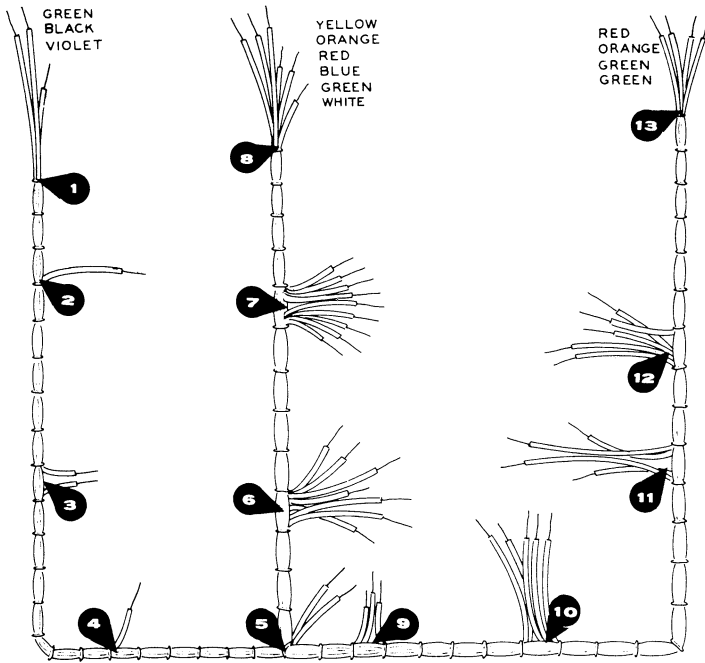

Detail 2B

- (✓) Place the wiring harness on the chassis as shown in Pictorial 2.
- ( ) Place the four leads at BO 13 through grommet HG. They will be connected later.

Connect the harness leads extending from BO 12 as follows:

- (✓) Connect the brown harness lead to lug 4 of tube socket V1 (NS).
- (✓) Connect the yellow harness lead to lug 1 of terminal strip R (NS).
- (✓) Connect the blue harness lead to lug 2 of terminal strip S (NS).
- ( ) Connect both red harness leads to lug 4 of terminal strip R (NS).

Connect the leads extending from BO 11 as follows:

- (✓) Connect both red harness leads to lug 2 of terminal strip Q (NS).
- ( ) Connect both brown harness leads to lug 4 of tube socket V2 (NS).

Connect the harness leads extending from BO 10 as follows:

- ( ) Connect the orange harness lead to lug 2 of octal socket CC (NS).
- ( ) Connect both brown harness leads to lug 3 of octal socket CC (NS).
- (✓) Connect both red harness leads to lug 4 of octal socket CC (NS).

Connect the harness leads extending from BO 9 as follows:

- (✓) Connect both red harness leads to lug 3 of control BE (S-2).
- (✓) Connect the white harness lead to lug 2 of control BE (S-1).

Connect the harness leads extending from BO 5 as follows:

- ( ) Connect the green harness lead to lug 6 of octal socket BD (S-1).
- (✓) Connect the black harness lead to lug 4 of terminal strip BC (NS).

Connect the harness leads extending from BO 6 as follows:

- ( ) Connect both blue harness leads to lug 1 of terminal strip L (NS).
- (✓) Connect both red harness leads to lug 3 of terminal strip L (NS).
- (✓) Connect the three brown harness leads to lug 3 of tube socket V3 (S-3).

Connect the harness leads extending from BO 7 as follows:

- (✓) Connect the brown harness lead to lug 4 of tube socket V4 (S-1).
- (✓) Connect both red harness leads to lug 1 of terminal strip F (NS).
- (✓) Connect both blue harness leads to lug 2 of terminal strip F (NS).
- (✓) Connect the violet harness lead to lug 3 of terminal strip F (NS).
- (✓) Connect the orange harness lead to lug 5 of terminal strip F (NS).
- (✓) Connect both yellow harness leads to lug 6 of terminal strip F (NS).

Connect the harness leads extending from BO 8 as follows:

- (✓) Connect the white harness lead to lug 3 of switch FE (S-1).
- (✓) Connect the yellow harness lead to lug 4 of switch FE (NS).
- (✓) Connect the green harness lead to lug 2 of control FD (S-1).
- (✓) Connect the blue harness lead to lug 1 of control FD (S-1).
- (✓) Place a length of sleeving over the orange harness lead and connect it to lug 3 of switch FG (S-1). Push the length of sleeving over the switch lug.
- (✓) Connect the red harness lead to lug 2 of switch FG (S-1).

Connect the harness lead extending from BO 4 as follows:

- (✓) Connect the green harness lead to lug 1 of phono socket BA (S-1).

Connect the harness leads extending from BO 3 as follows:

- (✓) Connect both brown harness leads to lug 3 of tube socket V7 (S-3).

Connect the harness lead extending from BO 2 as follows:

- (✓) Connect the brown harness lead to lug 4 of tube socket V6 (NS).

Connect the harness leads extending from BO 1 as follows:

- (✓) Connect the green harness lead to lug 1 of phone jack FA (S-1).
- (✓) Connect the black harness lead to lug 5 of control FB (S-1).
- (✓) Place the violet harness lead through rubber grommet HA. It will be connected later.

This completes the harness wiring on the bottom of the chassis. Continue with Initial Wiring.

## INITIAL WIRING

Refer to Pictorial 2 for the following steps.

- (✓) Connect a length of bare wire from lug 1 of terminal strip Q (S-1) to lug 5 of tube socket V2 (NS).
- (✓) Referring to Detail 2C prepare a 3-1/2" length of coaxial cable.

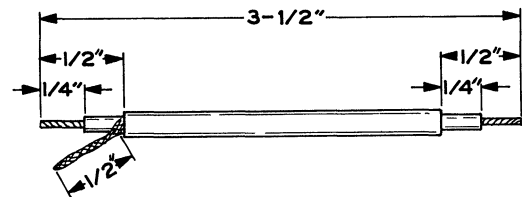

Detail 2C

- (✓) Connect the shield lead of the prepared cable to lug 5 (NS) and the inner conductor to lug 6 (S-1) of tube socket V2.
- (✓) At the other end of this cable connect the inner conductor to lug 2 of IF transformer P (S-1). Position this lead as shown in Pictorial 2.
- (✓) Connect one end of a 4-1/2" yellow wire to lug 8 of tube socket V2 (NS). Place the other end of this wire through grommet HD. It will be connected later.



- (✓) Connect a length of bare wire from lug 1 of octal socket CC (S-1) to lug 1 of phono socket BF (NS).
- (✓) Connect a length of bare wire between lug 8 (S-1) and the ground lug nearest lug 8 (S-1) of octal socket CC.
- (✓) Connect a length of bare wire from lug 5 of IF transformer P (S-1) to lug 1 of crystal socket N (S-1).
- (✓) Connect a length of bare wire from lug 3 of IF transformer P (S-1) to lug 1 of crystal socket M (S-1).
- (✓) Place one end of a length of bare wire through lug 2 of crystal socket M (NS) to lug 2 of crystal socket N (S-1). Now solder lug 2 of M (S-2). Connect the other end of this wire to lug 1 of tube socket V3 (NS).
- (✓) Connect a 2" red wire from lug 1 of IF transformer K (S-1) to lug 5 of tube socket V3 (S-1).
- (✓) Connect a length of bare wire from lug 8 of tube socket V4 (S-1) to lug 2 of BFO coil C (NS).
- (✓) Place one end of a length of bare wire through solder lug D (NS) to lug 5 of switch FE (S-1). Now solder solder lug D (S-2). Connect the other end of this wire to lug 1 of BFO coil C (S-1).
- (✓) Connect a 3-1/4" red wire from lug 6 of tube socket V4 (S-1) to lug 1 of IF transformer B (S-1).
- (✓) Connect a 3-1/2" red wire from lug 3 of IF transformer B (NS) to lug 3 of terminal strip F (NS).
- (✓) Connect a length of bare wire from lug 4 of IF transformer B (S-1) to solder lug E (NS).
- (✓) Connect a length of bare wire from lug 2 of IF transformer B (S-1) to lug 2 of tube socket V5 (NS).
- (✓) Connect a 5" yellow wire from lug 4 of switch FE (S-2) to lug 1 of terminal strip A (NS).

- (✓) Connect one end of a 7-3/4" red wire to lug 2 of switch FE (S-1). Place the free end of this wire through grommet HA. It will be connected later.
- (✓) Cut a 5" length of spiral shield and unwind 1/2" from one end. See Detail 2D. Now separate the spiral shield at a point 1-1/2" from this end.
- (✓) Cut a 5-1/2" yellow wire, a 5-1/2" brown wire, and a 7-1/2" red wire. Place these wires through the length of spiral shield from the end farthest from the break. The yellow and brown wires should be pushed through the break in the shield and the red wire should pass on through the shield. Refer to Detail 2D.

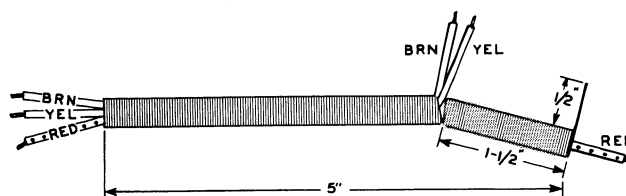

Detail 2D

- (✓) At the end of the prepared spiral shield with only the red wire extending, connect the shield lead to the ground lug nearest lug 3 of tube socket V6 (NS). Connect the red wire to lug 2 of tube socket V6 (S-1).
- (✓) At the break in the shield, connect the yellow wire to lug 6 (S-1) and the brown wire to lug 7 (NS) of tube socket V5.
- (✓) At the other end of this shield connect the red wire to lug 2 of control FB (S-1).
- (✓) Connect the yellow wire to lug 4 of switch FC (NS) and the brown wire to lug 5 of FC (NS).
- (✓) Solder lug 1 of control FB to the control solder lug.
- (✓) Connect a 2" brown wire from lug 4 of tube socket V5 (NS) to lug 4 of tube socket V6 (S-2).
- (✓) Connect a 3" red wire from lug 8 of tube socket V6 (S-1) to lug 1 of electrolytic capacitor H (NS).

- (✓) Connect a 3" red wire from lug 1 of electrolytic capacitor H (NS) to lug 3 of terminal strip L (NS).
- (✓) Connect a 3-1/2" red wire from lug 2 of electrolytic capacitor H (NS) to lug 1 of terminal strip G (NS).
- (✓) Connect a 2" red wire from lug 3 of electrolytic capacitor H (NS) to lug 7 of tube socket V7 (S-1).
- (✓) Connect a length of bare wire from lug 4 of tube socket V7 (S-1) to the solder lug mounted on V7 (S-1).

### COMPONENT INSTALLATION

Refer to Pictorial 3 (fold-out from Page 25) for the following steps.

NOTE: Before proceeding, read paragraph 3 under Chassis Wiring And Soldering on Page 9.

- (✓) C35. Connect a .005  $\mu$ fd disc ceramic capacitor from lug 3 of control FB (S-1) to lug 4 of switch FC (NS).
- (✓) R32. Connect a 1 megohm (brown-black-green) 1/2 watt resistor from lug 4 of switch FC (S-3) to lug 3 of terminal strip A (NS).
- (✓) R29. Connect a 47 K $\Omega$  (yellow-violet-orange) 1/2 watt resistor from lug 5 of switch FC (S-2) to lug 4 of terminal strip A (NS).
- (✓) R34. Connect a 1500  $\Omega$  (brown-green-red) 2 watt resistor between lugs 3 (S-2) and 4 (S-1) of phone jack FA.
- (✓) C29. Connect a .05  $\mu$ fd disc ceramic capacitor between lugs 1 (NS) and 2 (NS) of terminal strip A.
- (✓) C33. Connect a .05  $\mu$ fd disc ceramic capacitor between lugs 2 (NS) and 3 (NS) of terminal strip A.
- (✓) C32. Connect a 220  $\mu$ fd disc ceramic capacitor between lugs 2 (NS) and 4 (NS) of terminal strip A.

- (✓) Place one end of a length of bare wire through lug 3 (NS) to the center post (NS) of tube socket V5. Now solder lug 3 of V5. Connect the other end of this wire to the ground lug nearest lug 3 of V5 (NS).
- (✓) Place one end of a length of bare wire through lug 5 (NS) through the center post (NS) to lug 9 (NS) of tube socket V5. Now solder lug 5 (S-2). Connect the other end of this wire to the ground lug nearest lug 5 of V5 (NS).
- (✓) Connect a length of bare wire from lug 9 of tube socket V5 (S-2) to the ground lug nearest lug 9 of V5 (NS).
- (✓) R27. Connect a 2.2 megohm (red-red-green) 1/2 watt resistor from lug 8 of tube socket V5 (NS) to the ground lug nearest lug 5 of V5 (S-2).
- (✓) C36. Connect the positive (+) lead of a 10  $\mu$ fd electrolytic capacitor to lug 6 of tube socket V6 (NS). Connect the other lead of this capacitor to the ground lug nearest lug 3 of tube socket V5 (S-2).

Refer to Detail 3A for the following steps.

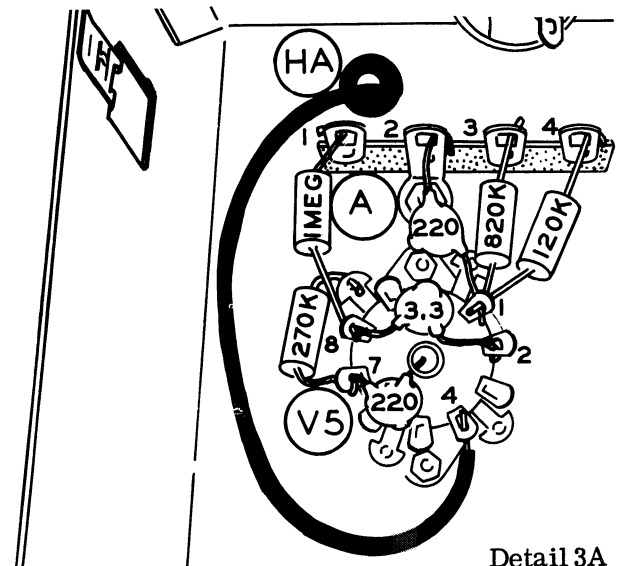

Detail 3A

- (✓) R30. Connect a 270 K $\Omega$  (red-violet-yellow) resistor from lug 7 of tube socket V5 (NS) to the ground lug nearest lug 9 of V5 (S-2).

- (✓) R26. Connect a 1 megohm (brown-black-green) 1/2 watt resistor from lug 1 of terminal strip A (S-3) to lug 8 of tube socket V5 (NS).
- (✓) R31. Connect an 820 K $\Omega$  (gray-red-yellow) 1/2 watt resistor from lug 3 of terminal strip A (S-3) to lug 1 of tube socket V5 (NS).
- (✓) R28. Connect a 120 K $\Omega$  (brown-red-yellow) 1/2 watt resistor from lug 4 of terminal strip A (S-3) to lug 1 of tube socket V5 (NS).
- (✓) C32. Connect a 220  $\mu\mu\text{f}$  disc ceramic capacitor from lug 2 of terminal strip A (S-4) to lug 1 of tube socket V5 (S-3).
- (✓) C31. Connect a 220  $\mu\mu\text{f}$  disc ceramic capacitor between lug 7 (S-3) and the center post (S-4) of tube socket V5.
- (✓) C34. Connect a 3.3  $\mu\mu\text{f}$  disc ceramic capacitor between lugs 2 (S-2) and 8 (S-3) of tube socket V5.
- (✓) Locate one of the pilot lamp sockets. Place the lead extending from this socket through grommet HA from the top side of the chassis. Connect this lead to lug 4 of tube socket V5 (S-2).

Refer to Pictorial 3 for the following steps.

- (✓) R35. Connect a 100  $\Omega$  (brown-black-brown) 1/2 watt resistor from lug 6 of tube socket V6 (S-2) to the ground lug nearest lug 8 of V6 (NS).
- (✓) Place one end of a length of bare wire through lug 5 (NS) to the center post (NS) of tube socket V6. Now solder lug 5 of V6 (S-2). Connect the other end of this wire to the ground lug nearest lug 6 of V6 (S-1).
- (✓) R37. Connect a 1000  $\Omega$  (brown-black-red) 1/2 watt resistor from lug 1 of tube socket V6 (S-1) to the ground lug nearest lug 4 of V6 (S-2).

Refer to Detail 3B for the following steps.

- (✓) C37. Connect a .005  $\mu\text{fd}$  1.4 kv disc ceramic capacitor between lug 9 (S-2) and the center post (S-2) of tube socket V6.

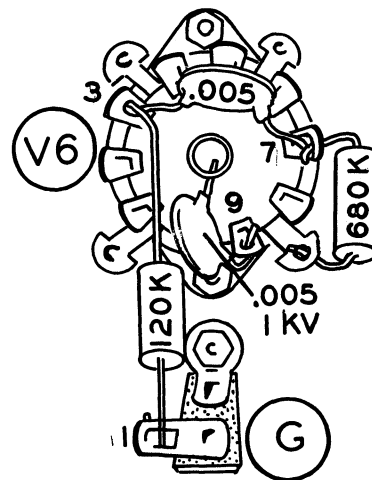

Detail 3B

- (✓) R36. Connect a 680 K $\Omega$  (blue-gray-yellow) 1/2 watt resistor from lug 7 of tube socket V6 (NS) to the ground lug nearest lug 8 of V6 (S-2).
- (✓) R38. Connect a 120 K $\Omega$  (brown-red-yellow) 1/2 watt resistor from lug 3 of tube socket V6 (NS) to lug 1 of terminal strip G (S-2).
- (✓) C38. Connect a .005  $\mu\text{fd}$  disc ceramic capacitor between lugs 3 (S-2) and 7 (S-2) of tube socket V6.

Refer to Pictorial 3 for the following steps.

- (✓) R44. Connect a 1500  $\Omega$  10 watt wire-wound resistor between lugs 1 (NS) and 3 (S-3) of electrolytic capacitor H.
- (✓) R43. Connect a 22 K $\Omega$  (red-red-orange) 1/2 watt resistor between lugs 1 (S-4) and 2 (S-2) of electrolytic capacitor H.
- (✓) C28. Connect a .005  $\mu\text{fd}$  disc ceramic capacitor from lug 3 of IF transformer B (S-2) to solder lug E (S-3).
- (✓) C40. Connect a 30  $\mu\mu\text{f}$  resin dipped mica capacitor from lug 2 of BFO coil C (S-2) to lug 1 of variable capacitor FF (S-1).
- (✓) Place one end of a length of bare wire through the center post (NS) of tube socket V4 to the solder lug mounted on V4 (NS). Connect the other end of this wire to lug 5 of V4 (S-1).

- (✓) R40. Connect a 10 K $\Omega$  (brown-black-orange) 1/2 watt resistor from lug 9 of tube socket V4 (NS) to the solder lug mounted on V4 (NS).
- (✓) C42. Connect a 30  $\mu$ f resin dipped mica capacitor from lug 9 of tube socket V4 (S-2) to lug 3 of BFO coil C (S-1).
- (✓) R21. Connect a 470  $\Omega$  (yellow-violet-brown) 1/2 watt resistor from lug 7 of tube socket V4 (NS) to lug 2 of terminal strip F (NS).
- (✓) R22. Connect a 10 K $\Omega$  (brown-black-orange) 1/2 watt resistor from lug 3 of tube socket V4 (NS) to lug 3 of terminal strip F (NS).
- (✓) C63. Connect a .1  $\mu$ f disc ceramic capacitor between lugs 2 (S-4) and 4 (S-1) of terminal strip F.
- (✓) R25. Connect a 6800  $\Omega$  (blue-gray-red) 1/2 watt resistor between lugs 1 (S-3) and 3 (S-4) of terminal strip F.
- (✓) PC1. Connect a parasitic choke (#45-43) from lug 2 of tube socket V4 (S-1) to lug 2 of IF transformer K (S-1).
- Refer to Detail 3C for the following steps.
- (✓) C26. Connect a .1  $\mu$ f disc ceramic capacitor between lug 7 (S-2) and the solder lug mounted on tube socket V4 (S-3).
- (✓) C27. Connect a .005  $\mu$ f disc ceramic capacitor between lug 3 (S-2) and the center post (NS) of tube socket V4.
- (✓) C39. Connect a .005  $\mu$ f disc ceramic capacitor between lug 1 (NS) and the center post (S-4) of tube socket V4.
- (✓) R39. Connect a 68 K $\Omega$  (blue-gray-orange) 1/2 watt resistor from lug 1 of tube socket V4 (S-2) to lug 5 of terminal strip F (S-2).
- Refer to Pictorial 3 for the following steps.
- (✓) R19. Connect a 100 K $\Omega$  (brown-black-yellow) 1/2 watt resistor from lug 6 of terminal strip F (S-3) to lug 4 of IF transformer K (NS).
- (✓) C25. Connect a .005  $\mu$ f disc ceramic capacitor from lug 4 of IF transformer K (S-2) to solder lug J (NS).
- (✓) C24. Connect a .005  $\mu$ f disc ceramic capacitor from lug 3 of IF transformer K (NS) to solder lug J (S-2).
- (✓) R18. Connect a 2200  $\Omega$  (red-red-red) 1/2 watt resistor from lug 3 of IF transformer K (S-2) to lug 3 of terminal strip L (NS).
- (✓) C64. Connect a .005  $\mu$ f disc ceramic capacitor between lugs 2 (S-1) and 3 (NS) of terminal strip L.
- (✓) R17. Connect a 47 K $\Omega$  (yellow-violet-orange) 1/2 watt resistor from lug 3 of terminal strip L (NS) to lug 6 of tube socket V3 (NS).
- (✓) R46. Connect a 100 K $\Omega$  (brown-black-yellow) 1/2 watt resistor between lugs 3 (S-7) and 1 (NS) of terminal strip L.
- (✓) R16. Connect a 100  $\Omega$  (brown-black-brown) 1/2 watt resistor from lug 1 of terminal strip L (S-4) to lug 7 of tube socket V3 (NS).
- (✓) Place one end of a length of bare wire through lug 4 (NS) to lug 2 (NS) of tube socket V3. Connect the other end to the solder lug mounted on V3 (NS).

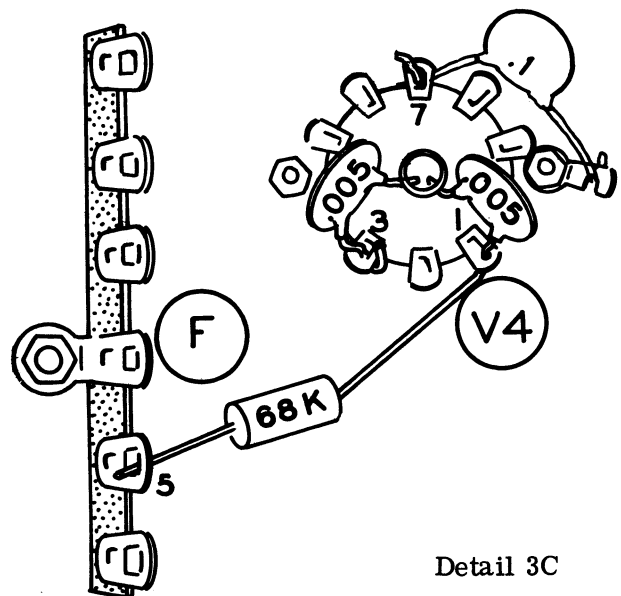

Detail 3C



- (✓) R15. Connect a 3900  $\Omega$  (orange-white-red) 1/2 watt resistor from lug 1 of tube socket V3 (S-2) to the solder lug mounted on V3 (S-2).
- (✓) C23. Connect a .005  $\mu$ fd disc ceramic capacitor between lugs 4 (S-3) and 6 (S-2) of tube socket V3.
- (✓) C22. Connect a .005  $\mu$ fd disc ceramic capacitor between lugs 7 (S-2) and 2 (S-2) of tube socket V3.
- (✓) C59. Connect a .005  $\mu$ fd 1.4 kv disc ceramic capacitor between lugs 2 (NS) and 3 (NS) of terminal strip BC.
- (✓) C60. Connect a .005  $\mu$ fd 1.4 kv disc ceramic capacitor between lugs 3 (S-2) and 4 (NS) of terminal strip BC.
- (✓) Connect a length of bare wire from lug 1 of octal socket BD (S-1) to the ground lug nearest lug 1 of BD (S-1).
- (✓) R24. Connect a 22 K $\Omega$  (red-red-orange) 1 watt resistor from lug 1 of control BE (S-1) to the ground lug nearest lug 7 of octal socket BD (S-1).
- (✓) C17. Connect a .005  $\mu$ fd disc ceramic capacitor between lugs 1 (NS) and 4 (S-3) of IF transformer P. Be sure to solder lug 4 of P to the solder lug nearest lug 4.
- (✓) R14. Connect a 1000  $\Omega$  (brown-black-red) 1/2 watt resistor from lug 1 of IF transformer P (S-2) to lug 4 of octal socket CC (S-3).
- (✓) C51. Connect a .005  $\mu$ fd disc ceramic capacitor from lug 3 of octal socket CC (S-3) to the ground lug nearest lug 3 of CC (S-1).
- (✓) C61. Connect a .005  $\mu$ fd disc ceramic capacitor from lug 2 of octal socket CC (S-2) to the ground lug nearest lug 1 of CC (S-1).
- (✓) Place one end of a length of bare wire through the center post (NS) to lug 5 (S-3) of tube socket V2. Connect the other end of this wire to the solder lug mounted on V2 (NS).
- (✓) R42. Connect a 100 K $\Omega$  (brown-black-yellow) 1/2 watt resistor from lug 9 of tube socket V2 (NS) to the solder lug mounted on V2 (NS).
- (✓) R12. Connect a 470  $\Omega$  (yellow-violet-brown) 1/2 watt resistor from lug 7 of tube socket V2 (NS) to the solder lug mounted on V2 (NS).
- (✓) C43. Connect a .005  $\mu$ fd disc ceramic capacitor from lug 1 of tube socket V2 (NS) to the solder lug mounted on V2 (NS).
- (✓) R11. Connect a 100 K $\Omega$  (brown-black-yellow) 1/2 watt resistor from lug 2 of tube socket V2 (NS) to the solder lug mounted on V2 (S-5).
- (✓) R10, C18. Referring to Detail 3D, prepare a 10  $\Omega$  (brown-black-black) resistor and a 30  $\mu$ fd resin dipped capacitor in a series combination (S-2). Place a length of clear plastic sleeving over this combination as shown.

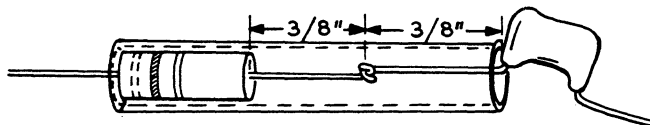

Detail 3D

- (✓) Connect the resistor lead of this combination to lug 2 of tube socket V2 (NS). Connect the capacitor lead to lug 5 of tube socket V1 (NS). Use sleeving on this lead.
- (✓) R13. Connect a 47 K $\Omega$  (yellow-violet-orange) 1/2 watt resistor from lug 3 of tube socket V2 (NS) to lug 2 of terminal strip Q (NS).

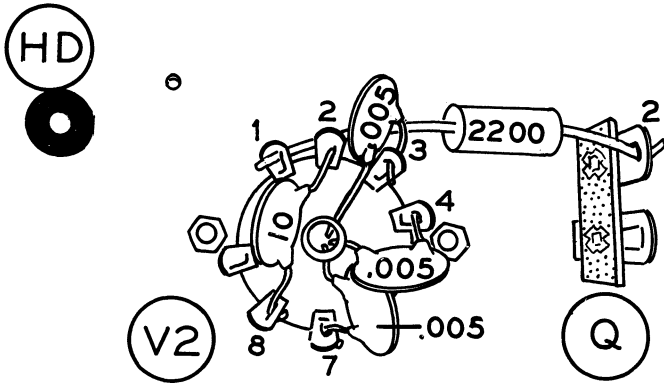

Detail 3E

Refer to Detail 3E for the following steps.

- (✓) C19. Connect a 10  $\mu\text{f}$  disc ceramic capacitor between lugs 2 (S-3) and 8 (NS) of tube socket V2.
- (✓) C21. Connect a .005  $\mu\text{f}$  disc ceramic capacitor between lug 3 (S-2) and the center post (NS) of tube socket V2.
- (✓) C53. Connect a .005  $\mu\text{f}$  disc ceramic capacitor between lug 4 (S-3) and the center post (NS) of tube socket V2.
- (✓) C20. Connect a .005  $\mu\text{f}$  disc ceramic capacitor between lug 7 (S-2) and the center post (S-5) of tube socket V2.
- (✓) R41. Connect a 2200  $\Omega$  (red-red-red) 1/2 watt resistor from lug 2 of terminal strip Q (S-4) to lug 1 of tube socket V2 (S-2).

Refer to Pictorial 3 for the following steps.

- (✓) R4. Connect a 150  $\Omega$  (brown-green-brown) 1/2 watt resistor from lug 2 of tube socket V1 (NS) to lug 2 of terminal strip S (NS).
- (✓) C9. Connect a .005  $\mu\text{f}$  disc ceramic capacitor between lugs 1 (S-1) and 2 (S-3) of terminal strip S.
- (✓) Place one end of a length of bare wire through the center post (NS) to lug 3 (S-1) of tube socket V1. Connect the other end of this wire through lug 7 (S-2) to the solder lug mounted on V1 (S-1).
- (✓) R3. Connect a 100 K $\Omega$  (brown-black-yellow) 1/2 watt resistor between lugs 1 (S-2) and 2 (NS) of terminal strip R.

- (✓) C8. Connect a .005  $\mu\text{f}$  disc ceramic capacitor between lugs 2 (NS) and 3 (NS) of terminal strip R.
- (✓) C65. Connect a .005  $\mu\text{f}$  disc ceramic capacitor between lugs 3 (NS) and 4 (NS) of terminal strip R.
- (✓) R8. Connect a 120 K $\Omega$  (brown-red-yellow) 1/2 watt resistor from lug 3 of terminal strip R (S-3) to lug 6 of tube socket V1 (NS).
- (✓) R7. Connect a 47 K $\Omega$  (yellow-violet-orange) 1/2 watt resistor from lug 4 of terminal strip R (NS) to lug 6 of tube socket V1 (NS).

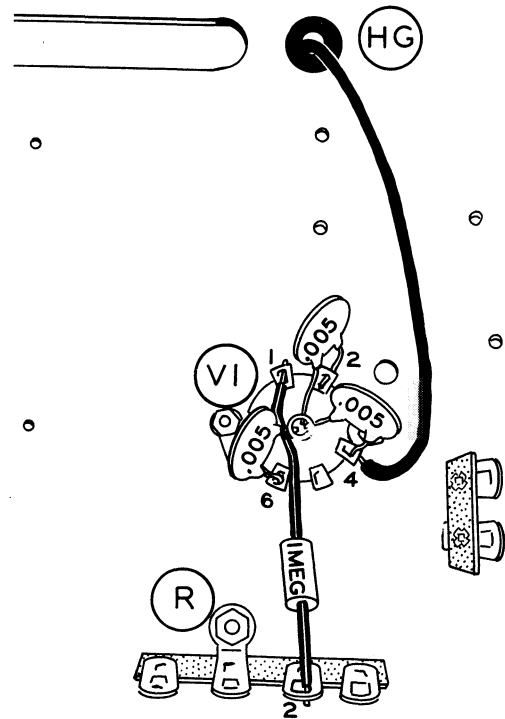

Detail 3F

Refer to Detail 3F for the following steps.

- (✓) C52. Connect a .005  $\mu\text{f}$  disc ceramic capacitor between lug 4 (NS) and the center post (NS) of tube socket V1.
- (✓) C10. Connect a .005  $\mu\text{f}$  disc ceramic capacitor between lug 6 (S-3) and the center post (NS) of tube socket V1.
- (✓) C66. Connect a .005  $\mu\text{f}$  disc ceramic capacitor between lug 2 (S-2) and the center post (S-5) of tube socket V1.

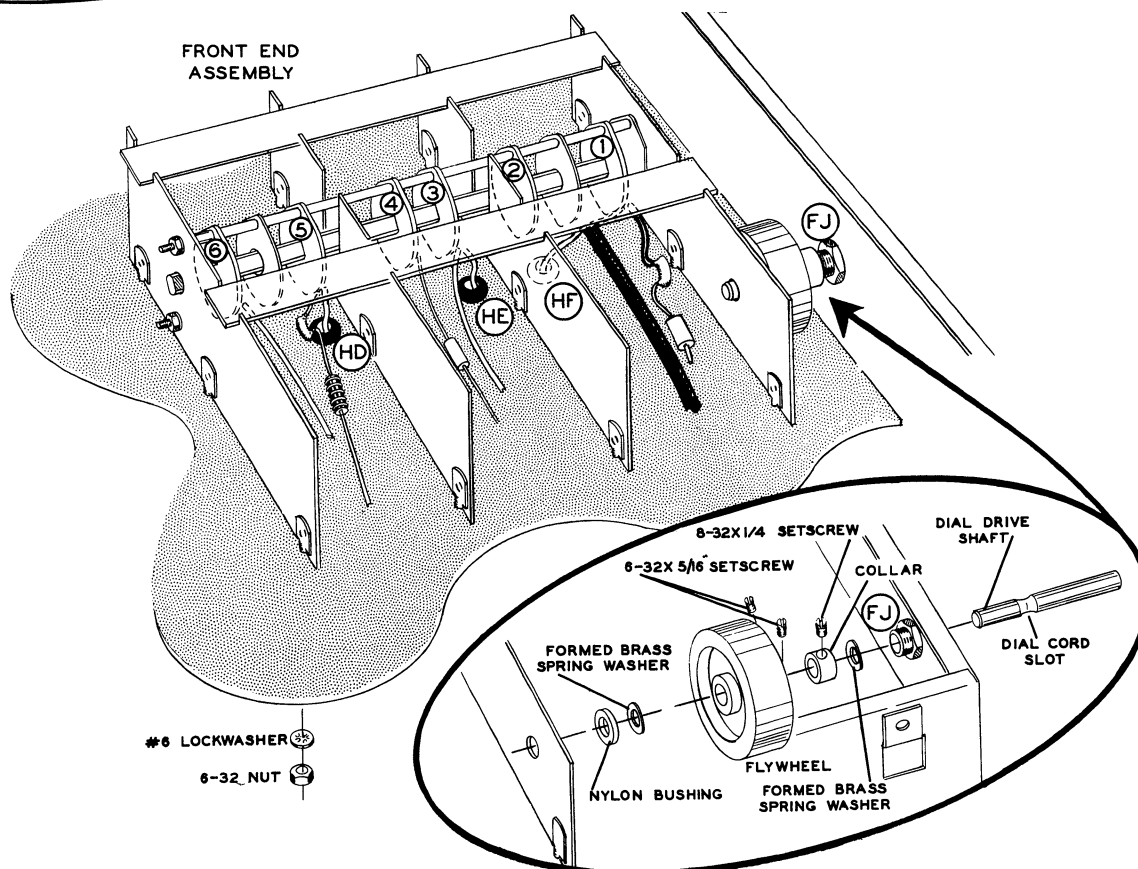

Detail 4A

- (✓) R2. Connect a 1 megohm (brown-black-green) 1/2 watt resistor from lug 2 of terminal strip R (S-3) to lug 1 of tube socket V1 (NS). Use sleeving on both leads.
- (✓) Locate the remaining pilot lamp socket and place its lead through grommet HG from the top of the chassis. Connect the end of this lead to lug 4 of tube socket V1 (S-3).

### FRONT END MOUNTING

Refer to Detail 4A for the following steps.

- (✓) Place the short end of the 2-1/2" dial drive shaft through bushing FJ from the front side of the front panel.
- (✓) Place a formed spring brass washer over the end of the shaft extending through the front panel. Start an 8-32 x 1/4" setscrew in the collar. Place the collar over the end of the dial drive shaft. Do not tighten the setscrew.
- (✓) Start two 6-32 x 5/16" setscrews in the flywheel. Place the flywheel over the end of the

dial drive shaft until the front edge of the flywheel is flush with the rear edge of the dial cord slot in the shaft. Now tighten the two setscrews in the flywheel.

- (✓) Place the remaining formed spring brass washer and the flat nylon bushing over the end of the dial drive shaft.
- (✓) Referring to Detail 4A, and Pictorial 4 (Page 26), place the front end assembly into place. Be sure that the yellow wire extending from wafer 1 of the BAND switch passes through grommet HF, the short yellow wire from wafer 3 passes through grommet HE, and the yellow wire from wafer 5 passes through grommet HD. Secure the assembly with #6 lockwashers and 6-32 nuts. Dress the free end of the remaining wires and component lead as shown. Before tightening the mounting hardware, be sure that all wires are out from under the front end assembly.
- (✓) Hold the flywheel tight against the front end assembly and push the collar, on the dial drive shaft against the formed spring brass washer and tighten the setscrew.

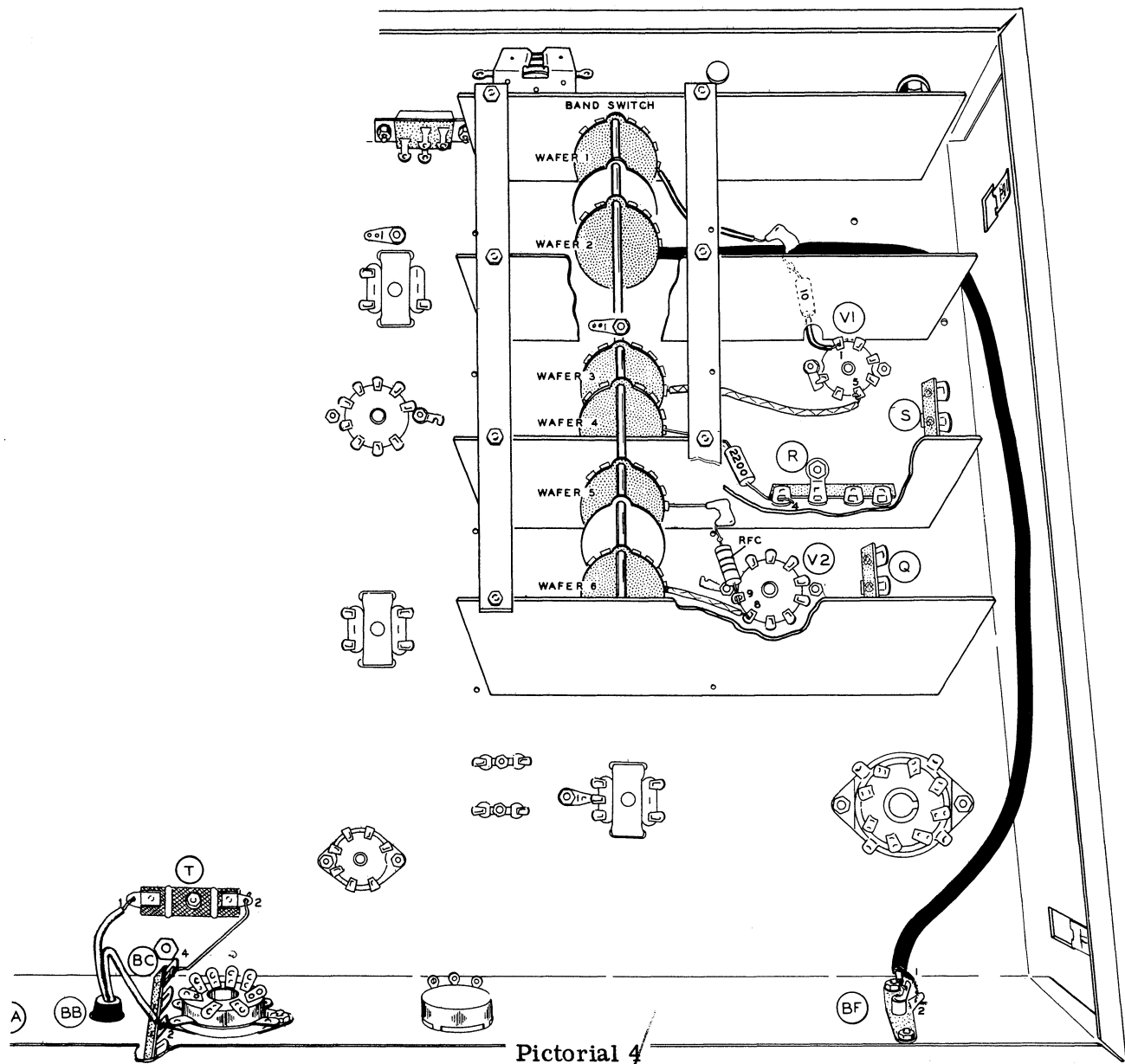

Refer to Pictorial 4 for the following steps.

- (-) Connect the free lead of the resistor capacitor series extending from wafer 1 of the BAND switch to lug 1 of tube socket V1 (S-2). Use sleeving.
- (✓) Connect the free end of the long yellow wire extending from wafer 3 of the BAND switch to lug 5 of tube socket V1 (S-2).
- (✓) Connect the free end of the 2200  $\Omega$  (red-red-red) 1/2 watt resistor extending from wafer 4 of the BAND switch to lug 4 of terminal strip R (S-5). Cut off any excess lead length.
- (✓) Connect the free lead of the capacitor choke combination extending from wafer 5 of the BAND switch to lug 9 of tube socket V2 (S-2). Cut off any excess lead length.
- (✓) Connect the free end of the yellow wire extending from wafer 6 of the BAND switch to lug 8 of tube socket V2 (S-3).
- (✓) Route the coaxial cable extending from wafer 2 of the BAND switch as shown and connect the inner conductor to lug 1 of phono socket BF (S-2). Connect the shield to lug 2 of BF (S-1).

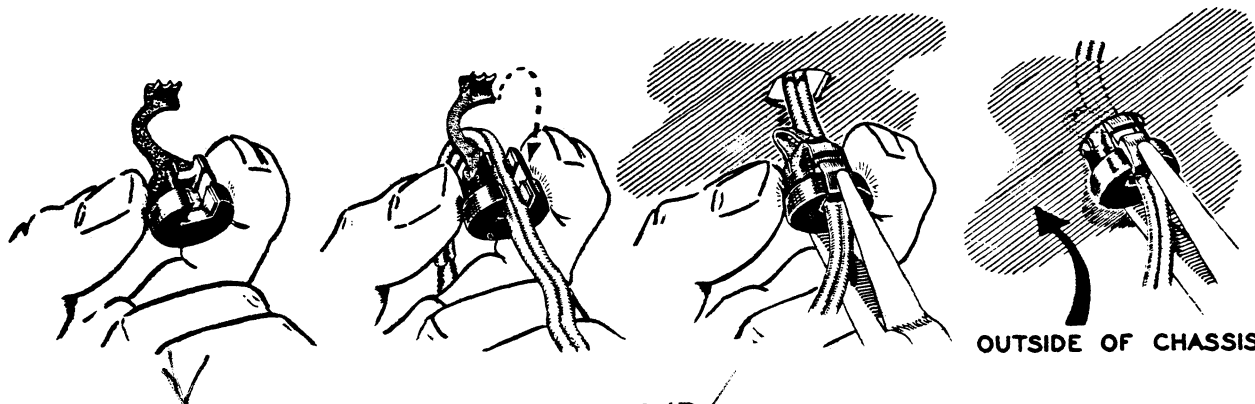

Detail 4B

- (✓) Referring to Detail 4B and Pictorial 4, ~~install the line cord and line cord strain relief at location BB on the rear apron. Leave 1-1/2" of line cord inside the chassis.~~
- (✓) Apply a small amount of solder to each line cord wire and then connect either wire to lug 2 of terminal strip BC (S-4). Connect the other wire to lug 1 of fuse block T (S-1).
- (✓) Connect a length of bare wire from lug 2 of fuse block T (S-1) to lug 4 of terminal strip BC (S-3), [S-3 if wired for 240 VAC operation]. Use sleeving.
- (✓) Connect either green harness wire extending through grommet HG to lug 4 (S-1) and the other green wire to lug 5 (S-1) of slide switch FK.
- (✓) Connect the orange harness wire extending through grommet HG to lug 5 of slide switch FL (S-1).
- (✓) Connect the red harness wire extending through grommet HG to lug 4 of slide switch FL (S-1).

This completes the wiring on the bottom of the chassis.

### CHASSIS TOP PARTS MOUNTING AND WIRING

Refer to Pictorial 5 for the following steps.

- (✓) Connect the yellow wire extending through grommet HF to lug 1 of the MAIN TUNING capacitor (NS).
- (✓) Connect the yellow wire extending through grommet HE to lug 2 of the MAIN TUNING capacitor (S-1).
- (✓) Connect the short yellow wire extending through grommet HD to lug 3 of the MAIN TUNING capacitor (S-1).
- (✓) Connect a 3" yellow wire from lug 1 of the MAIN TUNING capacitor (S-2) to lug 1 of variable capacitor FM (S-1).
- (✓) Connect the free end of the remaining yellow wire extending through grommet HD to lug 1 of variable capacitor FN (S-1).
- (✓) Connect the red harness lead extending from grommet HA to lug 1 (S-1) and the violet harness lead to lug 2 (S-1) of the meter.
- (✓) Turn the MAIN TUNING capacitor until the capacitor plates are fully meshed. Position the rim opening in the dial drum as shown in Pictorial 5 and tighten the setscrew. Make sure it rotates freely in the chassis cutout.

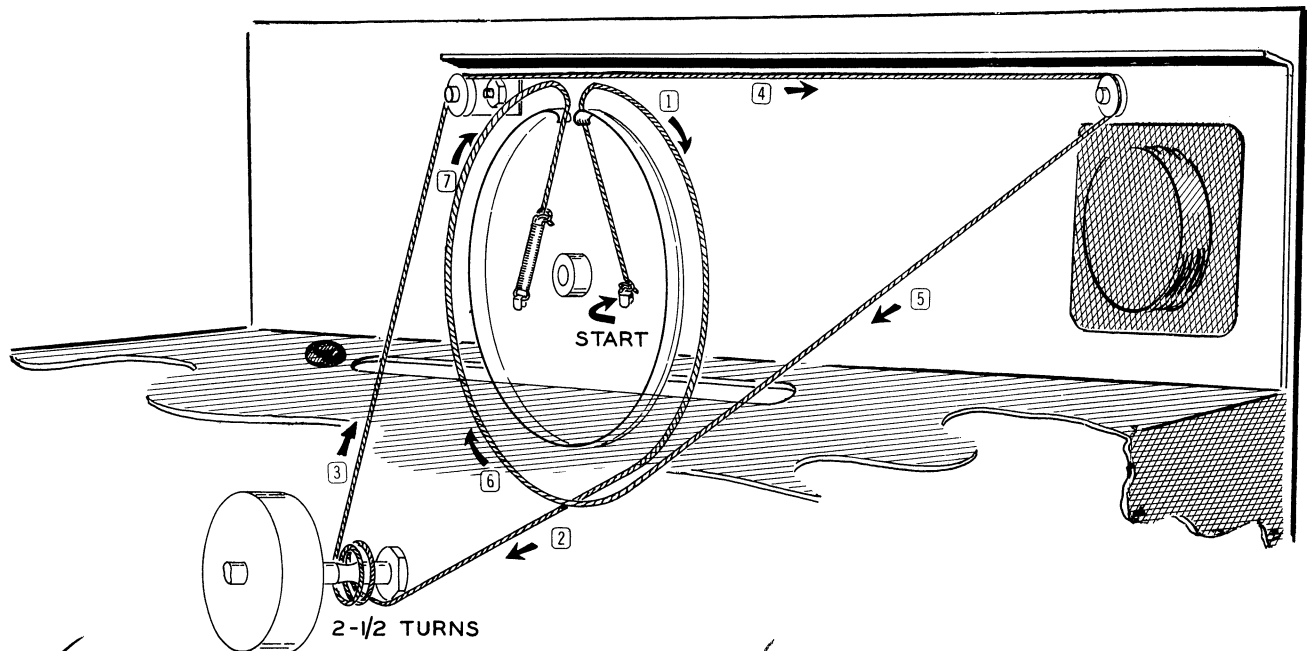

Detail 5A

- (1) Locate the dial cord and tie a loop in one end, approximately 1" from the end. Place this loop over the tab on the dial drum as shown in Detail 5A.
- (2) Referring to Detail 5A, finish stringing the dial cord on the dial drum, dial back plate assembly, dial drive shaft, and the dial pulley assembly. Tie the dial cord spring on the dial cord. Cut off any excess cord length. Attach the free end of the spring to the dial drum.
- (3) Install the large knob on the MAIN tuning shaft. Rotate the MAIN TUNING capacitor fully counterclockwise. Place the dial cord through the fingers on the bottom of the dial pointer. Holding the tuning capacitor plates closed slide the pointer on the dial cord until it is 1/8" to the left (as viewed from the front panel) of the 3.5 mc calibrating mark. Secure the pointer to the dial cord by squeezing the fingers on the cord. Be careful not to cut the cord.
- (4) Referring to Detail 5B, start two 6-32 x 1/4" screws in one of the shaft couplers. Place one end of this coupler on the shaft of the variable capacitor at FM. Tighten the setscrew.
- (5) Place one end of the 1-7/8" extension shaft through the ANT TRIM hole in the front panel and into the open end of the shaft coupler. Tighten the setscrew. The end of the shaft should extend 3/8" beyond the front of the panel.
- (6) Start two 6-32 x 1/4" screws in the remaining shaft coupler and secure one end to the variable capacitor shaft at FN.

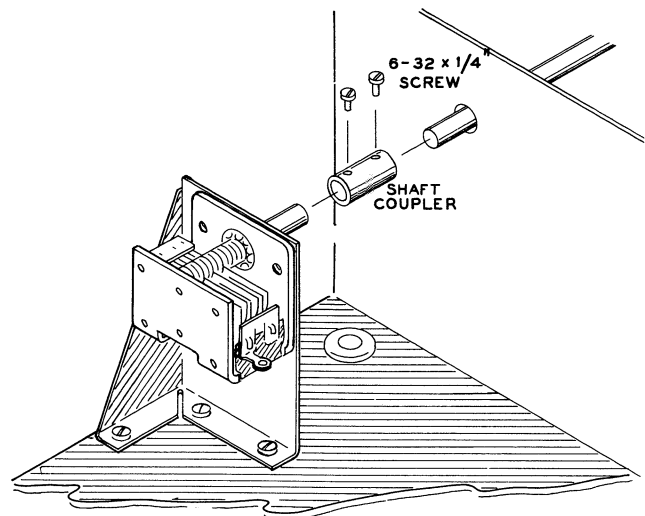

Detail 5B

- (✓) Place one end of the remaining shaft through the CAL RESET hole in the front panel and into the open end of the shaft coupler on FN. Tighten the setscrew. The end of the shaft should extend 3/8" beyond the front of the panel.
- (✓) Insert all tubes in their respective tube sockets and install the tube shields.
- (✓) Install the 1/2 ampere fuse in the fuse block. (Use a 1/4 ampere fuse if the Receiver was wired for 240 VAC operation. NOTE: This fuse is not furnished with the kit.)
- (✓) Place a pilot lamp in each pilot lamp socket. Install the sockets on the pilot lamp brackets.
- (✓) Install a 1680.70 kc crystal in its crystal socket and the 1682.40 kc crystal in its crystal socket.
- (✓) Install the two small knobs on the CAL RESET and ANT TRIM control shafts.
- (✓) Install the remaining medium knobs on the remaining shafts. Turn each shaft fully counterclockwise and set the pointer on the knob at the beginning of rotation.

This completes the assembly of your Receiver. Continue with the Initial Test Procedure.

## INITIAL TEST

- (✓) Locate the octal plug and octal plug cap. Referring to Figure 1, connect a bare jumper wire between lugs 1 (S-1) and 6 (S-1). Now install the octal plug cap.
- (✓) Plug the prepared octal plug into the accessory socket on the rear apron.

If an ohmmeter is available measure the resistance from lug 1 of terminal strip G to ground. After approximately 30 seconds the resistance reading should be 30 K $\Omega$  or over. If it is lower, refer to the In Case Of Difficulty section of the manual.

- ( ) Set all front panel controls as follows:

AF GAIN	OFF
RF GAIN	Maximum clockwise
BFO TUNE	12 o'clock
BAND Switch	80 meters
MAIN TUNING	3.5 mc
ANL	OFF
AVC	OFF
BFO	OFF
CAL	OFF
STBY-REC	REC

- ( ) Connect an 8  $\Omega$  speaker to Speaker jack BA on the rear apron.
- ( ) Plug the line cord into an AC outlet supplying the voltage for which the Receiver was wired (105-125 or 210-250 volts). CAUTION: Connecting the Receiver to the wrong line voltage could result in severe damage.

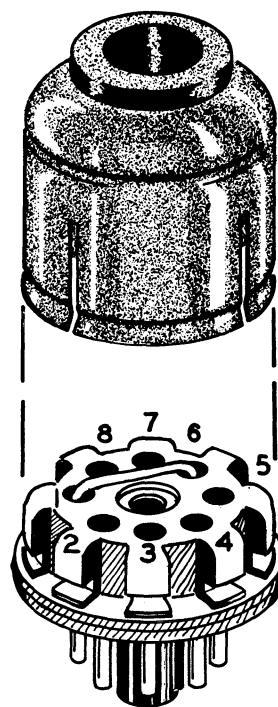

Figure 1

- ( ) Turn the AF GAIN control to the 12 o'clock position. The pilot lamps and all tube filaments should glow. After several seconds, a rushing noise should be heard in the speaker. If these conditions exist, unplug the line cord and proceed to the Alignment section of this manual. If they do not, unplug the line cord and refer to the In Case Of Difficulty section.

## ALIGNMENT

### IF TRANSFORMER ALIGNMENT AND METER ZERO ADJUSTMENT

Equipment Required: An amplitude modulated RF signal generator and an AC voltmeter.

( ) Set all front panel controls as follows:

AF GAIN	12 o'clock
RF GAIN	Maximum clockwise
BFO TUNE	12 o'clock
BAND Switch	80 meters
MAIN TUNING	3.5 mc
ANL	OFF
AVC	OFF
BFO	OFF
CAL	OFF
STBY-REC	REC

- ( ) Connect a jumper wire from lug 9 of tube socket V2 to lug 1 of terminal strip Q. This disables the oscillator for IF transformer alignment.
- ( ) Connect one lead of the AC voltmeter to lug 1 of Speaker jack BA on the rear apron. Connect the other test lead to ground.
- ( ) Make sure that the speaker is still connected to the Speaker jack.
- ( ) Connect the positive or hot lead of the signal generator to the center lug of the ANTenna connector on the rear apron.
- ( ) Turn all of the equipment on and let it warm up for approximately 30 minutes to stabilize all circuits.
- ( ) Place the meter on the 3 or 5 volt range and set the generator for a high output level. The output of the generator should be reduced as the alignment procedure increases the sensitivity of the Receiver to keep the meter reading at approximately 1-1/2 volts.
- ( ) Start alignment of the IF transformer by adjusting the signal generator for maximum indication on the meter. The generator reading at this time may be slightly above or below the 1682 kc IF frequency.

- ( ) Adjust the bottom slug of the IF transformer T3 for maximum meter indication. Then adjust the top slug of T3 for a maximum indication. Proceed to transformer T2 and adjust the bottom slug for a maximum indication, then adjust the top slug.
- ( ) Adjust the top slug of T1 for a maximum indication, and then adjust the bottom slug.
- ( ) Adjust the signal generator frequency for a maximum meter indication. Then repeat the above IF transformer alignment steps.
- ( ) Repeat the entire procedure described above, each time adjusting the signal generator until further adjustment does not cause an increase in meter reading.

Refer to Figure 2 for the locations of the transformers called for in the following steps.

- ( ) Place the BFO switch in the ON position. Turn the modulation switch on the signal generator to off. Turn the slug in the BFO coil until you obtain a zero beat. Be sure that the BFO tuning knob is in the 12 o'clock position and that the signal generator is peaked for maximum voltage reading.
- ( ) Rotate the BFO tuning knob each side of the 12 o'clock position. For the same amount of rotation in each direction, the tone should be the same frequency except at the extreme clockwise and counterclockwise positions, where there is nonlinearity of the variable capacitor. If the tone is not the same frequency, readjust the BFO coil.
- ( ) Turn the BFO switch to OFF and turn the modulation of the generator on.
- ( ) This completes the alignment of the IF stages in your Receiver. Disconnect the test equipment and remove the jumper wire from lug 9 of tube socket V2 to lug 1 of terminal strip Q.
- ( ) Temporarily place a short from the center lug of the ANTenna connector to ground with a screwdriver.



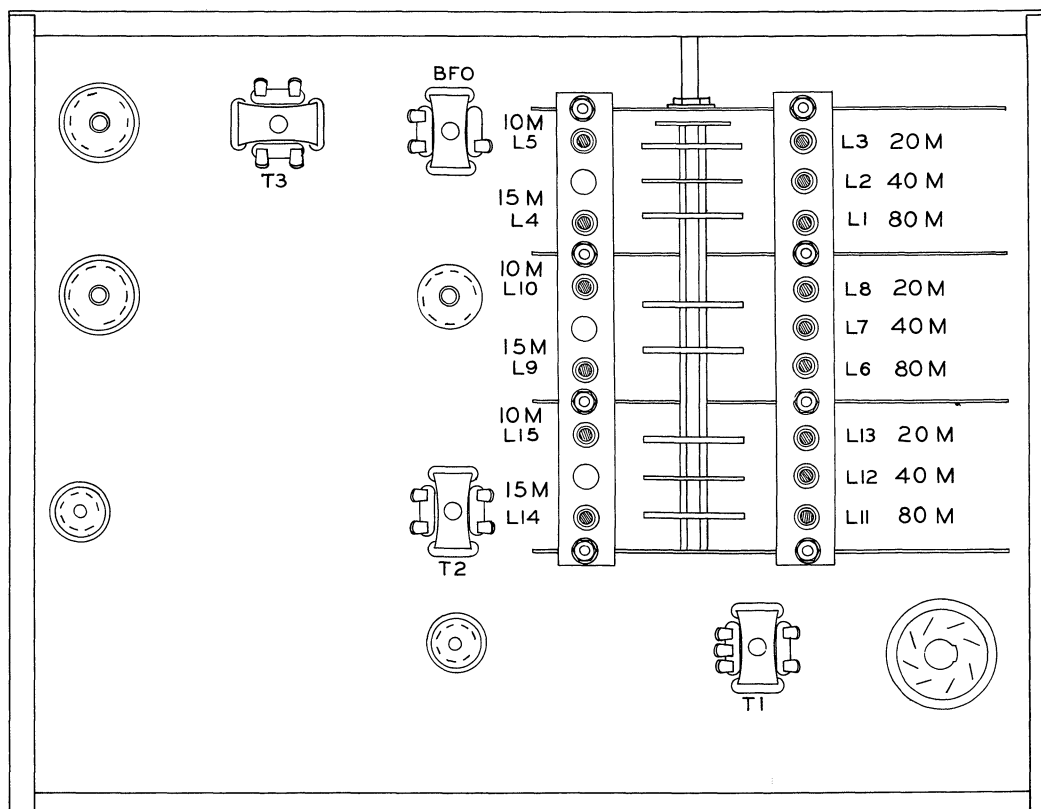

Figure 2

- ( ) Temporarily short the antenna connector to ground. Be sure that the RF GAIN control is in its maximum clockwise position and the AVC switch is in the AVC position. Adjust the METER ZERO ADJ control for a zero reading on the "S" meter.
- ( ) Remove the short from the antenna connector.

### FRONT END ALIGNMENT

In order to obtain optimum results from the Receiver, the front end assembly should be aligned with an accurate amplitude modulated RF signal generator and an AC voltmeter.

It is very important that the signal generator be very accurate. Therefore, the generator should be calibrated against a crystal calibrator or receiver of known accuracy. If the HRA-10-1 Crystal Calibrator has been purchased, it should be assembled at this time and used to calibrate the signal source.

When performing the following steps, bear in mind that the front end assembly has been preset by the manufacturer, however, due to differences in tubes and assembly techniques, some realignment will be necessary. Usually this will consist of not more than 1/2 turn of the coil slugs.

- ( ) Set all front panel controls as follows:
- |             |                                  |
|-------------|----------------------------------|
| AF GAIN     | Maximum clockwise                |
| RF GAIN     | Maximum clockwise                |
| BFO TUNE    | 12 o'clock                       |
| MAIN TUNING | As indicated in Alignment chart. |
| BAND Switch | As indicated in Alignment chart. |
| BFO         | OFF                              |
| ANL         | OFF                              |
| AVC         | OFF                              |
| STBY-REC    | REC                              |
| CAL RESET   | 12 o'clock                       |
| ANT TRIM    | 12 o'clock                       |
- ( ) Connect the RF signal generator to the ANT-enna connector.
- ( ) Connect the AC voltmeter across the Speaker jack.
- ( ) Complete each step as indicated in the following chart. Refer to Figure 3 for the location of each coil. Be sure to keep the signal generator level as low as possible while still obtaining a usable reading of the meter, this should be just above the normal noise level.

FRONT END ALIGNMENT CHART			
BAND SWITCH POSITION	RECEIVER AND GEN. FREQ.	ADJUST FOR MAX	SECTION BEING ADJUSTED
80 meters	3.50 mc	L11 *	Oscillator
	3.75 mc**	L1 and L6	Antenna and mixer coils
40 meters	7.00 mc	L12 *	Oscillator
	7.15 mc**	L2 and L7	Antenna and mixer coils
20 meters	14.00 mc	L13 *	Oscillator
	14.15 mc**	L3 and L8	Antenna and mixer coils
15 meters	21.00 mc	L14 *	Oscillator
	21.25 mc**	L4 and L9	Antenna and mixer coils
10 meters	28.00 mc	L15 *	Oscillator
	29.00 mc**	L5 and L10	Antenna and mixer coils

\*There will be no signal heard until these coils are peaked near the correct setting. Once the correct setting is found, carefully adjust for a maximum reading.

\*\*Set the Receiver and generator frequency as indicated in the chart and adjust the CAL RESET until the signal is heard.

## FINAL ASSEMBLY

Refer to Figure 3 (fold-out from Page 26) for the following steps.

- ( ) Install four rubber feet on the bottom plate as shown. Use 6-32 x 3/8" screws, #8 flat steel washers, #6 lockwashers, and 6-32 nuts.
- ( ) Mount the bottom plate to the chassis with #6 sheet metal screws.
- ( ) Place the cabinet cover over the chassis and secure it on each side with two 6-32 x 1/4" painted truss head screws.

NOTE: The blue and white identification label shows the Model Number and Production Series

Number of your kit. Refer to these numbers in any communications with the Heath Company; this assures you that you will receive the most complete and up-to-date information in return.

- ( ) Install the identification label in the following manner:
  1. Select a location for the label where it can easily be seen when needed, but will not show when the unit is in operation. This location might be on the rear panel or the top of the chassis, or on the rear or bottom of the cabinet.
  2. Carefully peel away the backing paper. Then press the label into position.

## INSTALLATION AND OPERATION

### CONTROLS

AF GAIN - Turns the Receiver ON or OFF, and varies the volume in the speaker or headphones.

RF GAIN - Varies the amount of gain in the RF and IF amplifier stages.

BFO TUNE - Makes it possible to tune the injected BFO signal either side of the IF center frequency for Single Side Band (SSB) and CW reception.

BAND - Selects one of the five Amateur bands: 80, 40, 20, 15, and 10 meters.

CAL RESET - Provides fine adjustment of the oscillator portion of the tuning capacitor for calibration points.

ANT TRIM - Peaks the signal at the frequency being received.

MAIN TUNING - Tunes in the desired station.

MUTING - Muting provisions have been incorporated in this Receiver. The jumper installed in the octal plug in a previous step should be removed and replaced with two separate wires. These wires are then connected to an antenna relay so that when the relay is in the receive position, the wires are shorted together activating the Receiver; when the relay is in the transmit position, the wires are open muting the Receiver. When this method of muting is used the STBY-REC switch is left in the REC position.

### AM OPERATION

STBY-REC Switch - REC  
 CAL -OFF Switch - OFF  
 BAND Switch - Desired Band  
 BFO-OFF Switch - OFF  
 AVC-ON Switch - ON  
 RF GAIN - Maximum clockwise  
 ANL-OFF - OFF  
 AF GAIN - Comfortable listening level

- ( ) Rotate the MAIN tuning capacitor until an AM signal is tuned in. Proper tuning of the AM signal will be indicated by maximum deflection of the "S" meter.
- ( ) Rotate the ANT TRIM capacitor for maximum signal strength. Once this adjustment has been made, it should not be necessary to readjust it except when changing bands.

NOTE: When listening to an extremely strong signal, the RF GAIN control should be "backed off," turned counterclockwise, to prevent blocking of the Receiver.

### CW OPERATION

STBY-REC Switch - REC  
 CAL-OFF Switch - OFF  
 BAND Switch - Desired band  
 BFO-OFF - BFO  
 BFO-TUNE - 12 o'clock  
 AVC-OFF - OFF  
 RF GAIN - Comfortable listening  
 AF GAIN - 3 o'clock

- ( ) Rotate the MAIN tuning capacitor until a CW station is located.
- ( ) Adjust the BFO TUNE control for the most comfortable listening tone.
- ( ) It is usually best to adjust the listening level using the RF GAIN control. This provides maximum RF amplification for a weak signal.

### SSB OPERATION

For SSB reception, set the controls as explained for CW operation, except turn the AVC

switch to AVC and adjust the BFO TUNE control as follows: The BFO TUNE control will normally be set at 10 o'clock for upper SSB stations and 2 o'clock for lower SSB stations. Upper sideband transmission is usually used on the 10, 15, and 20 meter bands. Lower sideband transmission is usually found on 40 and 80 meters. Should you find it impossible to tune in a SSB station, reverse the BFO TUNE control setting, as this station may be transmitting on the other sideband.

As with CW reception the listening level should be adjusted with the RF GAIN control, with the AF GAIN control in the 3 o'clock position.

## ANTENNA

The Receiver will operate using a long wire attached to the antenna connector, however, for the best results the antenna should have an impedance of 50 to 75  $\Omega$ . This could be a dipole type antenna. The dipole should be constructed for the band that you desire to receive. Naturally, if this Receiver is to be used in conjunction with a transmitter, the transmitting antenna should also be used for reception. For this

type of operation, a method for switching the antenna from the transmitter to the Receiver must be used.

If you wish to construct a dipole type of antenna, we suggest that you refer to the ARRL Handbook, an Antenna Handbook, or one of the periodical amateur radio magazines. These references are available at most Radio-TV Distributors.

## IN CASE OF DIFFICULTY

1. Recheck the wiring. Trace each lead in colored pencil on the Pictorial as it is checked. It is frequently helpful to have a friend check your work. Someone who is not familiar with the unit may notice something consistently overlooked by the constructor.
2. It is interesting to note that about 90% of the kits that are returned for repair, do not function properly due to poor connections and soldering. Therefore, many troubles can be eliminated by reheating all connections to make sure that they are soldered as described in the Proper Soldering Techniques section of this manual.
3. Check to be sure that all tubes are in their proper locations. Make sure that all tubes light up properly.
4. Check the tubes with a tube tester or by substitution of tubes of the same types and known to be good.
5. Check the values of the parts. Be sure that the proper part has been wired into the circuit, as shown in the pictorial diagrams and as called out in the wiring instructions.
6. Check for bits of solder, wire ends or other foreign matter which may be lodged in the wiring.
7. If, after careful checks, the trouble is still not located and a voltmeter is available, check voltage readings against those shown on the Schematic Diagram. NOTE: All voltage readings were taken with an 11 megohm input vacuum tube voltmeter. Voltages may vary as much as 10%.
8. A review of the Circuit Description will prove helpful in indicating where to look for trouble.

NOTE: In an extreme case where you are unable to resolve a difficulty, refer to the Service and Warranty section of the "Kit Builders Guide," and to the "Factory Repair Service" information on Page 36 of this Manual.

SPECIFIC PROBLEMS	
PROBLEM	CHECK
Filaments do not light.	<ol style="list-style-type: none"> <li>1. Check fuse.</li> <li>2. Check filament wiring.</li> <li>3. Open tube filament - Check for continuity with an ohmmeter.</li> <li>4. Check power transformer wiring against Pictorial 2.</li> </ol>
Filaments light, but no sound with GAIN controls turned fully clockwise.	<ol style="list-style-type: none"> <li>1. Make sure the STBY-REC Switch is not in STBY position, check muting circuit.</li> <li>2. Check wiring of the GAIN controls.</li> </ol> <div style="border: 1px solid black; padding: 5px; margin: 5px 0;"> <p>CAUTION: When making the following checks, do not touch the chassis with your other hand. Be sure that the chassis is not connected to an earth ground and that you touch only the specified lug on the tube socket.</p> </div> <ol style="list-style-type: none"> <li>3. Turn the Receiver on and place a small screwdriver on lug 7 of tube socket V6, then touch your finger to the metal portion of the screwdriver; a low pitched hum should be audible.</li> <li>4. Now place the screwdriver on lug 2 of tube socket V6. Again touch your finger to the metal portion, this time the hum should be louder. If no hum is present check the components of tube V6 and the wiring to the speaker jack.</li> </ol>
Audio present - no signals can be heard.	<p>CAUTION: When making the following tests, do not touch the chassis with your other hand.</p> <ol style="list-style-type: none"> <li>1. Place a small screwdriver on lug 2 of tube socket V4 and with your finger, touch the metal portion of the screwdriver. A low pitched hum should be heard.  If no hum is present, check the components around tube socket V4.</li> <li>2. Similarly, make the screwdriver test on lug 1 of tube socket V3. The hum should be louder.</li> <li>3. Similarly, make the screwdriver test on lug 2 of tube socket V2. The hum should be louder.</li> <li>4. Similarly, repeat the screwdriver test on lug 1 of tube socket V1. The hum should be louder.  If no hum is present or if the hum level does not increase, check the components on the circuit around the tube sockets.</li> </ol>



## FACTORY REPAIR SERVICE

You can return your completed kit to the Heath Company Service Department to have it repaired for a minimum service fee. (Kits that have been modified will not be accepted for repair.) If you wish, you can deliver your kit to a nearby Heath Authorized Service Center. These centers are listed in your Heathkit catalog.

To be eligible for replacement parts under the terms of the warranty, equipment returned for factory repair service, or delivered to a Heath Authorized Service Center, must be accompanied by the invoice or the sales slip, or a copy of either. If you send the original invoice or sales slip, it will be returned to you.

If it is not convenient to deliver your kit to a Heath Authorized Service Center, please ship it to the factory at Benton Harbor, Michigan and follow the following shipping instructions:

Prepare a letter in duplicate, containing the following information:

Your name and return address.

Date of purchase.

A brief description of the difficulty.

The invoice or sales slip, or a copy of either.

Your authorization to ship the repaired unit back to you C.O.D. for the service and shipping charges, plus the cost of parts not covered by the warranty.

Attach the envelope containing one copy of this letter directly to the unit before packaging, so that we do not overlook this important information. Send the second copy of the letter by separate mail to Heath Company, Attention: Service Department, Benton Harbor, Michigan.

Check the equipment to see that all parts and screws are in place. (Do not include wooden cabinets when shipping receivers, tuners, amplifiers, or TV sets, as these are easily damaged in shipment.) Then, wrap the equipment in heavy paper. Place the equipment in a strong carton, and put at least **THREE INCHES** of resilient packing material (shredded paper, excelsior, etc.) on all sides, between the equipment and the carton. Seal the carton with gummed paper tape, and tie it with a strong cord. Ship it by prepaid express, United Parcel Service, or insured parcel post to:

Heath Company  
Service Department  
Benton Harbor, Michigan 49022

## REPLACEMENT PARTS PRICE LIST

PART No.	PRICE Each	DESCRIPTION	PART No.	PRICE Each	DESCRIPTION
<b>RESISTORS</b>			<b>SWITCHES-CONTROLS</b>		
1-41	.10	10 $\Omega$ 1/2 watt	10-57	.35	10 K $\Omega$ tab-mount control
1-3	.10	100 $\Omega$ 1/2 watt	10-131	.55	10 K $\Omega$ control
1-66	.10	150 $\Omega$ 1/2 watt	19-72	.95	500 K $\Omega$ control w/SPST switch
1-6	.10	470 $\Omega$ 1/2 watt	60-18	.15	SPST slide switch
1-9	.10	1000 $\Omega$ 1/2 watt	60-36	.30	DPDT slide switch
1-44	.10	2200 $\Omega$ 1/2 watt	<b>TERMINAL STRIPS-SOCKETS-JACK-PLUGS</b>		
1-46	.10	3900 $\Omega$ 1/2 watt	431-10	.10	3-lug terminal strip
1-19	.10	6800 $\Omega$ 1/2 watt	431-12	.10	4-lug terminal strip
1-20	.10	10 K $\Omega$ 1/2 watt	431-15	.10	1-lug terminal strip
1-22	.10	22 K $\Omega$ 1/2 watt	431-16	.10	2-lug terminal strip
1-25	.10	47 K $\Omega$ 1/2 watt	431-45	.10	6-lug terminal strip
1-60	.10	68 K $\Omega$ 1/2 watt	431-40	.10	4-lug terminal strip
1-26	.10	100 K $\Omega$ 1/2 watt	434-34	.15	7-pin phenolic tube socket
1-121	.10	120 K $\Omega$ 1/2 watt	434-35	.30	7-pin ceramic tube socket
1-30	.10	270 K $\Omega$ 1/2 watt	434-36	.30	9-pin ceramic tube socket
1-34	.10	680 K $\Omega$ 1/2 watt	434-39	.15	Octal socket
1-68	.10	820 K $\Omega$ 1/2 watt	434-42	.10	Phono socket
1-35	.10	1 megohm 1/2 watt	434-43	.20	9-pin molded tube socket
1-37	.10	2.2 megohm 1/2 watt	434-56	.15	9-pin phenolic tube socket
1-5-1	.10	22 K $\Omega$ 1 watt	434-74	.15	Crystal socket
1-14-2	.20	1500 $\Omega$ 2 watt	434-85	.20	Pilot lamp socket
3-11-10	.20	1500 $\Omega$ 10 watt wire-wound	436-21	.95	Phone jack
<b>CAPACITORS</b>			438-6	.35	Octal plug
20-100	.15	30 $\mu\mu\text{f}$ resin dipped	438-4	.10	Phono plug
21-3	.10	10 $\mu\mu\text{f}$ disc ceramic	440-1	.20	Octal plug cap
21-33	.10	3.3 $\mu\mu\text{f}$ disc ceramic	<b>HARDWARE</b>		
21-22	.10	220 $\mu\mu\text{f}$ disc ceramic	250-4	.05	4-40 x 3/8" round head machine screw
21-48	.15	.05 $\mu\text{fd}$ disc ceramic	250-8	.05	#6 x 3/8" sheet metal screw
21-81	.35	.1 $\mu\text{fd}$ disc ceramic	250-18	.05	8-32 x 3/8" round head machine screw
21-27	.10	.005 $\mu\text{fd}$ disc ceramic	250-43	.05	8-32 x 1/4" setscrew
21-72	.20	.005 $\mu\text{fd}$ 1.4 KV disc ceramic	250-49	.05	3-48 x 1/4" screw
25-4	.50	10 $\mu\text{fd}$ 25 V electrolytic	250-56	.05	6-32 x 1/4" screw
25-9	1.15	20-20-20 $\mu\text{fd}$ 300 V twist-prong electrolytic	250-70	.05	6-32 x 3/16" flat head screw
26-84	4.15	15-15-15 $\mu\mu\text{f}$ 3-gang variable	250-89	.05	6-32 x 3/8" screw
26-64	1.40	21 $\mu\mu\text{f}$ single-section variable	250-100	.05	6-32 x 5/16" setscrew
<b>COIL-TRANSFORMERS-CHOKE</b>			250-116	.05	6-32 x 1/4" truss head machine screw (black)
40-429	.90	1682 kc BFO coil	250-138	.05	6-32 x 3/16" screw
45-43	.25	Parasitic choke wound on 47 $\Omega$ resistor	252-1	.05	3-48 nut
51-84	2.20	Audio output transformer	252-3	.05	6-32 nut
52-17	1.65	Interstage IF transformer	252-4	.05	8-32 nut
52-50	1.35	Input IF transformer	252-7	.05	Control nut
54-122-24	6.00	Power transformer	252-15	.05	4-40 nut
			252-22	.05	6-32 speednut



PART No.	PRICE Each	DESCRIPTION	PART No.	PRICE Each	DESCRIPTION
<b>Hardware (cont'd.)</b>			<b>SHAFTS-FLYWHEEL-BUSHINGS-KNOBS</b>		
253-9	.05	#8 flat steel washer	453-35	.15	1/4" diameter x 4-3/8" long shaft
253-10	.05	Control flat washer	453-90	.10	1/4" x 1-7/8" shaft
253-36	.05	Formed spring brass washer	453-114	.10	1/4" x 2-1/2" dial cord drive shaft
253-49	.10	Flat nylon washer	454-12	.50	Flywheel
254-1	.05	#6 lockwasher	455-9	.15	3/8" x 3/8" bushing
254-2	.05	#8 lockwasher	455-15	.10	1/4" x 1/4" collar
254-4	.05	Control lockwasher	456-7	.25	Metal coupling
254-7	.05	#3 lockwasher	462-257	.55	1-9/16" diameter green knob
254-9	.05	#4 lockwasher	462-122	.20	Gray knob with skirt and pointer
255-30	.10	Spacer	462-258	.30	9/16" diameter green knob with white pointer mark
258-1	.05	Dial cord spring			
259-1	.05	#6 solder lug			
259-6	.05	#6 small solder lug			
259-10	.05	Control solder lug			
260-7	.05	IF transformer clip			
260-29	.25	Crystal holding clip			
<b>GROMMETS-WIRE</b>			<b>METAL PARTS</b>		
73-1	.10	3/8" rubber grommet	90-358	2.80	Top cover
73-4	.10	5/16" rubber grommet	100-362	.30	Dial drum
89-1	.35	Line cord with plug	100-369-1	.70	Dial back plate assembly
134-40	2.60	Wiring harness	100-370	.15	Pulley bracket assembly
206-4	.15	Length spiral shield	100-640	1.00	Front panel
340-8	.05/ft	Length #22 bare wire	110-8	20.35	Front end tuner assembly
343-2	.10/ft	Length coax cable	200-332-1	4.15	Chassis
344-51	.05/ft	Length brown hookup wire	204-449	.30	Variable capacitor mounting bracket
344-52	.05/ft	Length red hookup wire	204-450	.10	Pilot lamp bracket
344-54	.05/ft	Length yellow hookup wire	204-451	.10	Pilot lamp bracket
346-4	.05/ft	Length sleeving 1/16" diameter	205-260	.90	Chassis bottom plate
346-2	.05/ft	Length sleeving 3/16" diameter	205-337	.10	Dial spacer plate
			205-350-1	.15	Meter spacer plate
<b>TUBES-CRYSTALS-PILOT LAMPS-FUSE</b>			<b>MISCELLANEOUS</b>		
404-184	5.00	1680.70 kc ±.005% tolerance crystal	75-24	.10	Line cord strain relief
404-185	5.00	1682.40 kc ±.005% tolerance crystal	206-3	.20	9-pin tube shield
407-90	5.00	Meter	206-25	.15	7-pin tube shield
411-64	.80	6X4 tube	261-9	.05	Rubber foot
411-90	.95	6BA6 tube	349-3	.05/ft	Length dial cord
411-113	1.50	6BJ7 tube	422-1	.25	Fuse block
411-124	1.50	6EA8 tube	463-31	.30	Dial pointer
411-126	1.05	6BZ6 tube	481-2	.10	Capacitor mounting wafer
411-161	2.20	6EB8 tube	490-1	.10	Alignment tool
412-20	.20	#47 pilot lamp	490-5	.10	Nut starter
421-20	.30	1/2 ampere slow-blow fuse	464-23-2	1.45	Dial plate (plastic)
			331-6	.15	Solder
				2.00	Manual (see front cover for part number)



## REPLACEMENT PARTS PRICE LIST FOR THE PREASSEMBLED FRONT END

This list is provided so that you may order replacement parts for the preassembled front end of your Model HR-10B Receiver. If you order a part, give the Part Number and Description.

PART No.	PRICE Each	DESCRIPTION	PART No.	PRICE Each	DESCRIPTION
<b>CAPACITORS</b>			<b>Coils (cont'd.)</b>		
20-77	.15	24 $\mu\mu\text{f}$ silver mica	40-419	.70	10 meter mixer
20-99	.15	22 $\mu\mu\text{f}$ silver mica	40-420	.70	15 meter mixer
20-100	.15	30 $\mu\mu\text{f}$ silver mica	40-421	.70	20 meter mixer
20-78	.15	56 $\mu\mu\text{f}$ silver mica	40-422	.70	40 meter mixer
20-119	.15	90 $\mu\mu\text{f}$ silver mica	40-423	.70	80 meter mixer
20-102	.15	100 $\mu\mu\text{f}$ silver mica	40-424	.80	10 meter oscillator
20-105	.20	180 $\mu\mu\text{f}$ silver mica	40-425	.75	15 meter oscillator
20-103	.15	150 $\mu\mu\text{f}$ silver mica	40-426	.75	20 meter oscillator
20-111	.20	230 $\mu\mu\text{f}$ silver mica	40-427	.80	40 meter oscillator
20-126	.25	255 $\mu\mu\text{f}$ silver mica	40-428	.70	80 meter oscillator
20-114	.20	270 $\mu\mu\text{f}$ silver mica			
21-7	.10	33 $\mu\mu\text{f}$ disc ceramic	<b>MISCELLANEOUS</b>		
21-27	.10	.005 $\mu\text{fd}$ disc ceramic	1-41	.10	10 $\Omega$ 1/2 watt resistor
21-65	.10	25 $\mu\mu\text{f}$ tubular ceramic	1-44	.10	2200 $\Omega$ 1/2 watt resistor
21-66	.10	50 $\mu\mu\text{f}$ tubular ceramic	45-43	.25	RF choke
			63-299	5.00	5-position rotary switch (6-section)
<b>COILS</b>			100-360	.60	Assembly shield, bandswitch end plate
40-414	.75	10 meter antenna	100-361	.55	Assembly shield, bandswitch partition
40-415	.75	15 meter antenna	205-335	.20	Coil mounting plate
40-416	.75	20 meter antenna			
40-417	.80	40 meter antenna			
40-418	.70	80 meter antenna			

To order parts, use the Parts Order Form furnished with this kit. If a Parts Order Form is not available, refer to Replacement Parts in the Kit Builders Guide.

The above prices apply only on purchases from the Heath Company where shipment is to a U.S.A. destination. Add 10% (minimum 25 cents) to the price when ordering from an authorized Service Center or Heathkit Electronic Center to cover local sales tax, postage and handling. Outside the U.S.A. parts and service are available from your local Heathkit source and will reflect additional transportation, taxes, duties and rates of exchange.

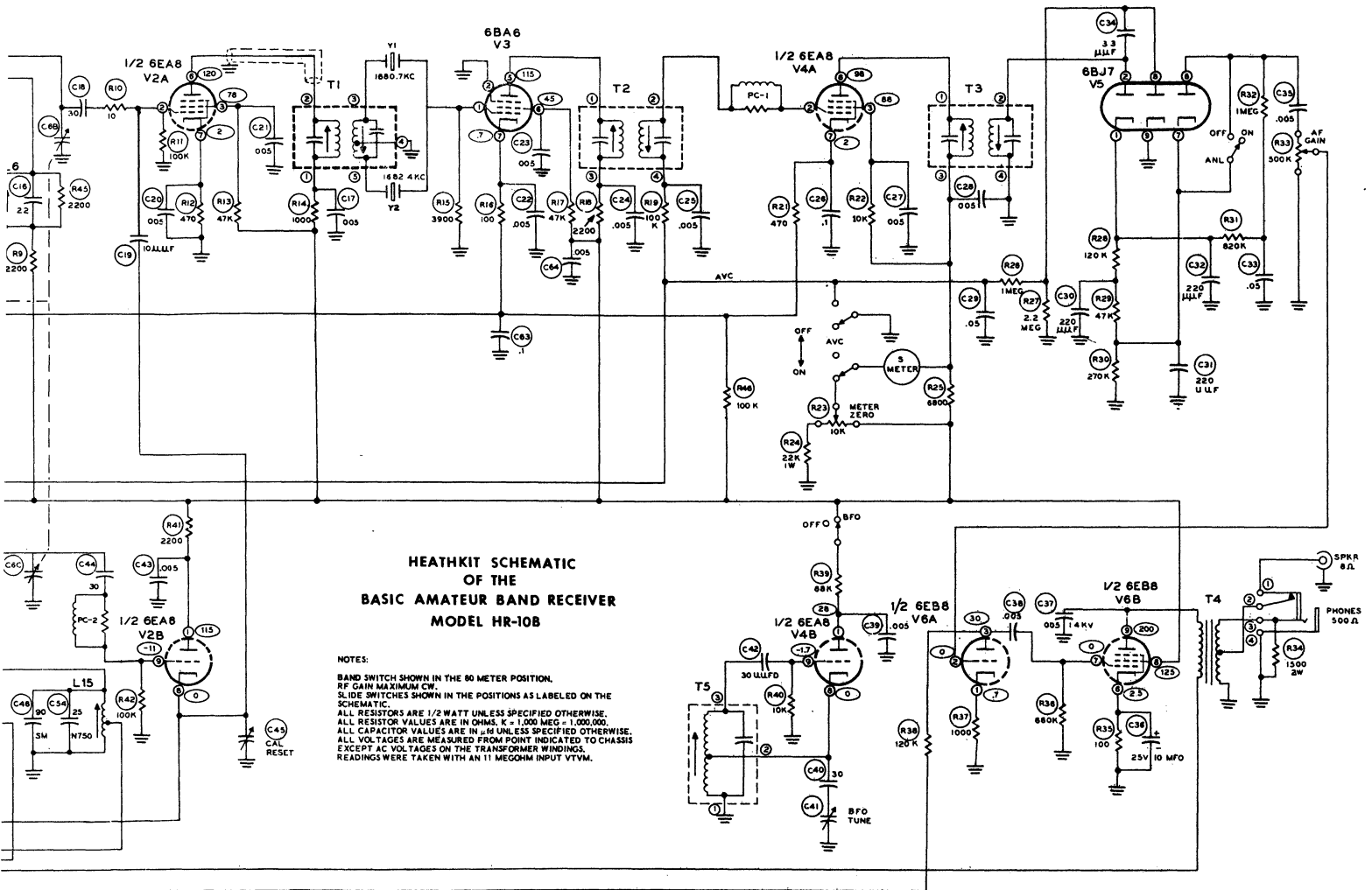

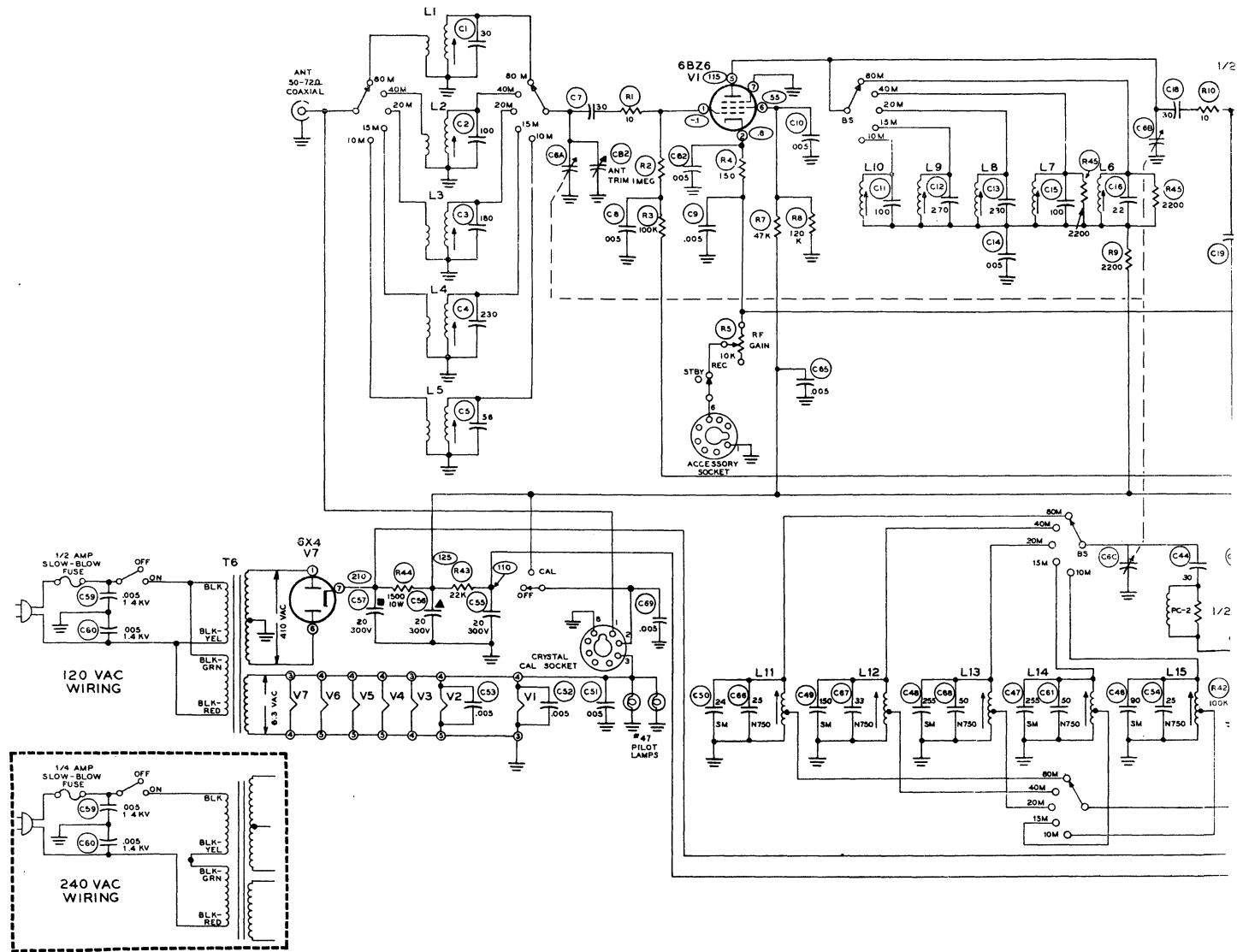

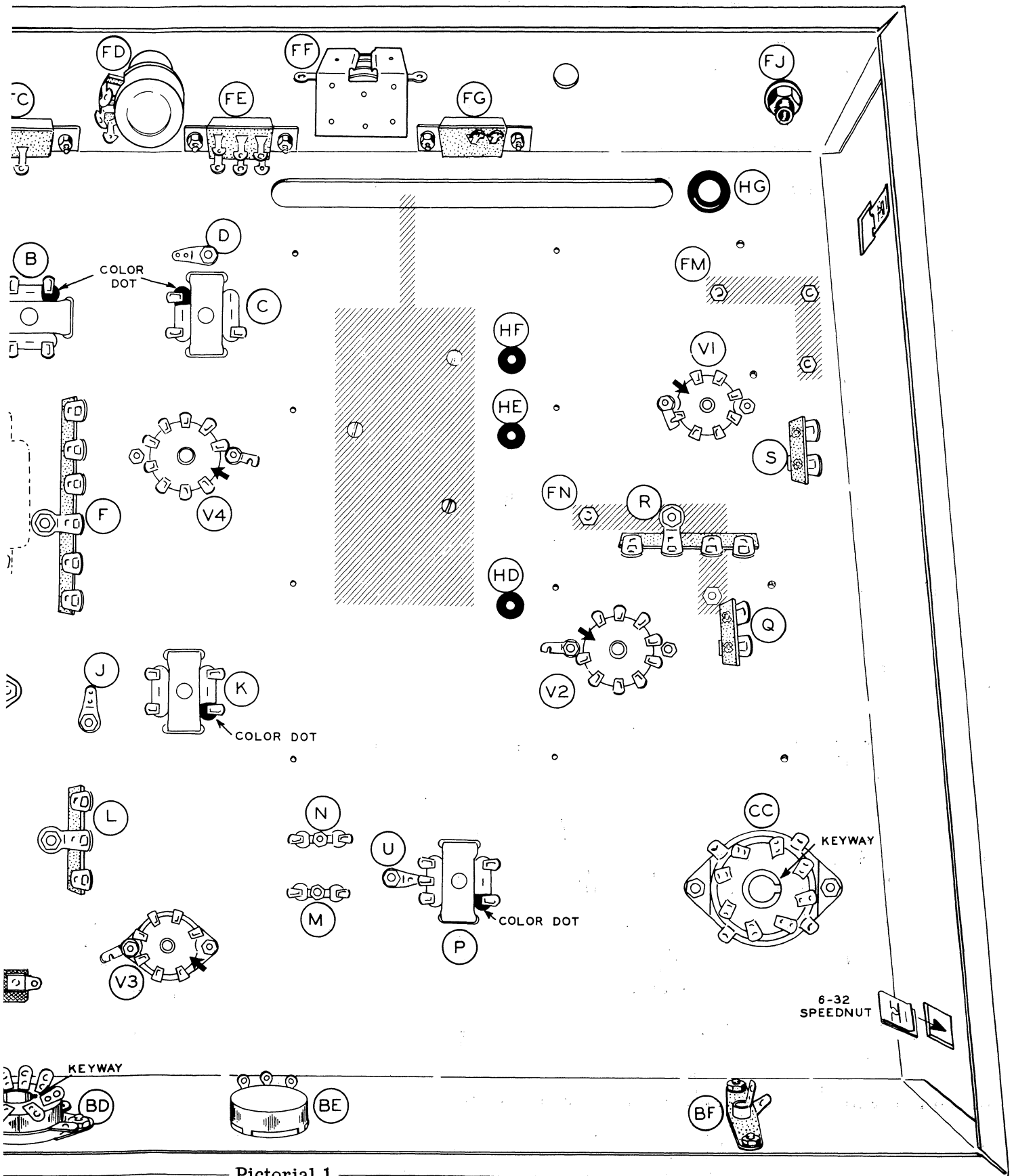

Pictorial 1

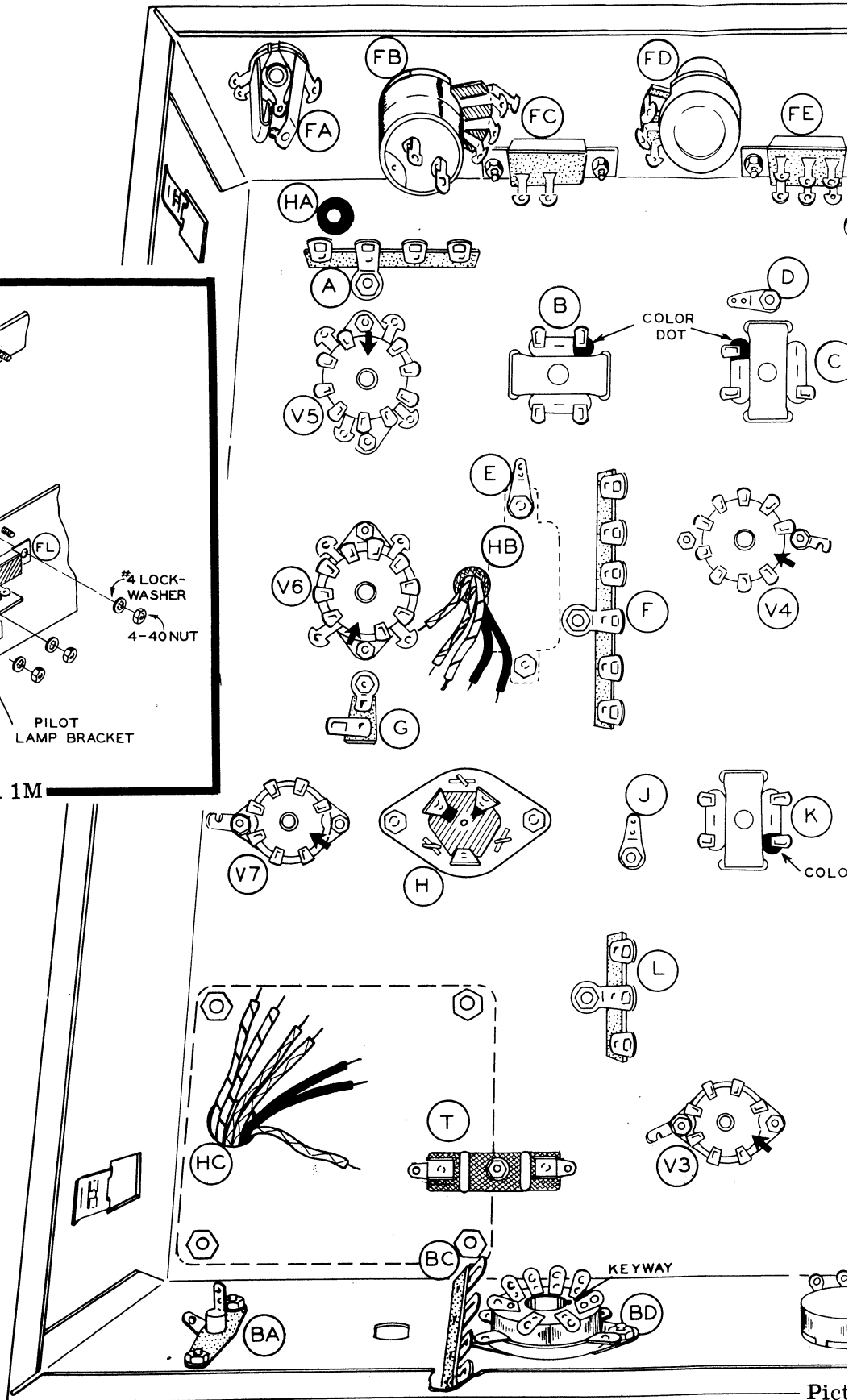
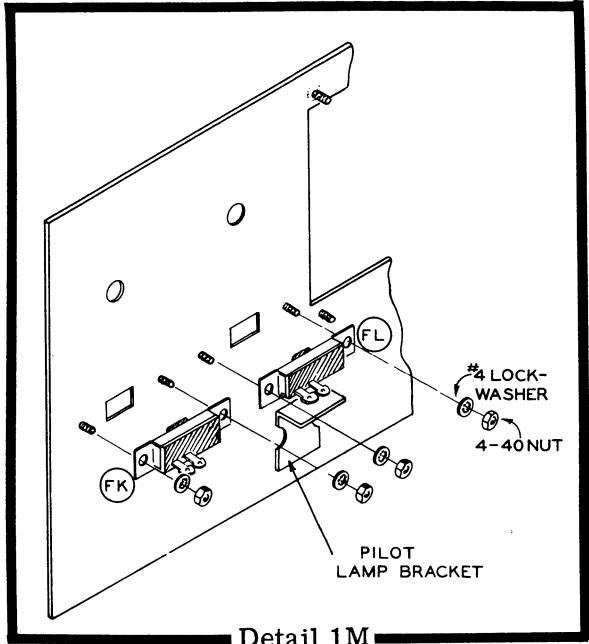

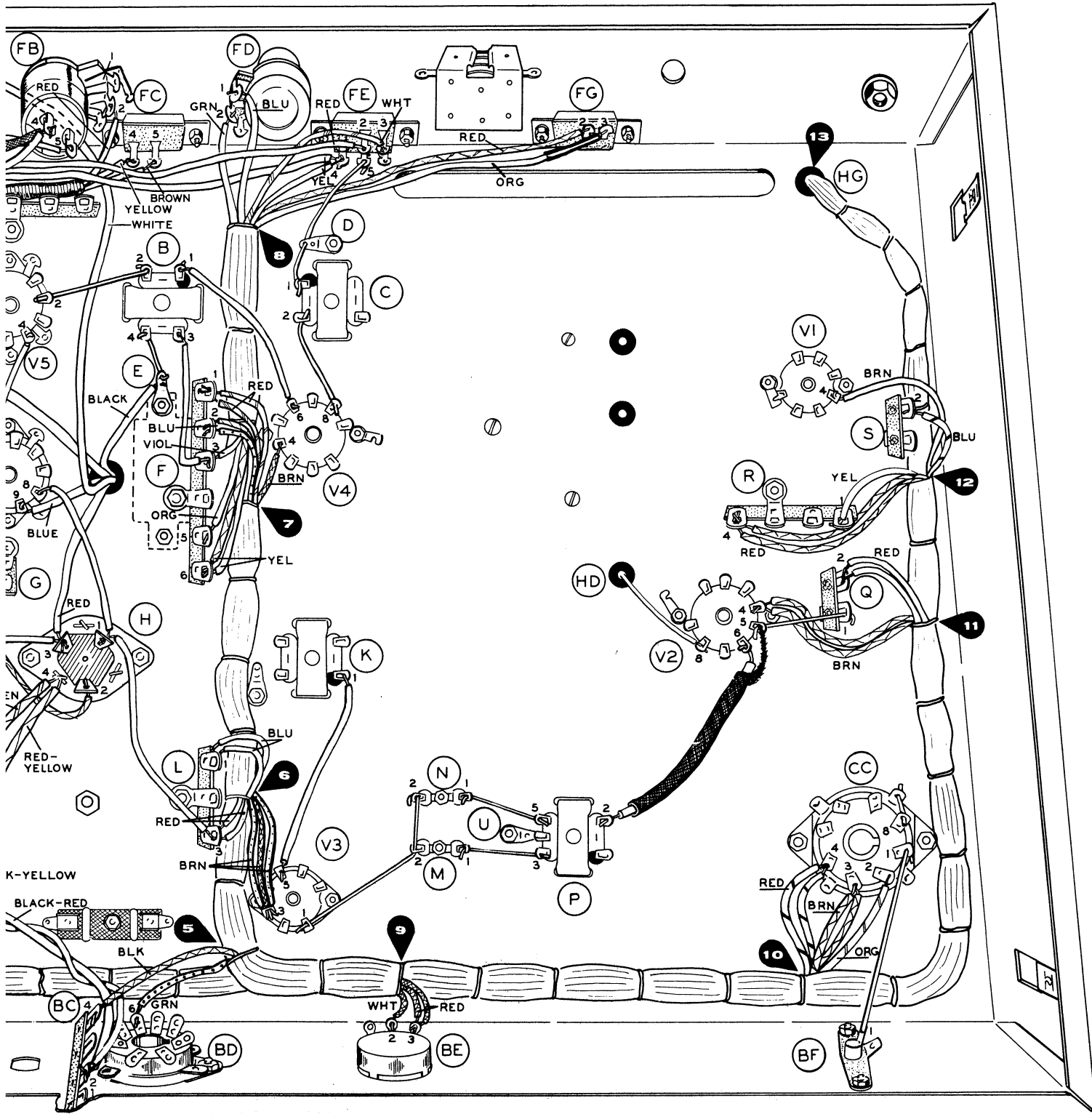

POWER TRANSFORMER WIRES ARE SHOWN HERE FOR 120 VAC WIRING.

Pictorial 2

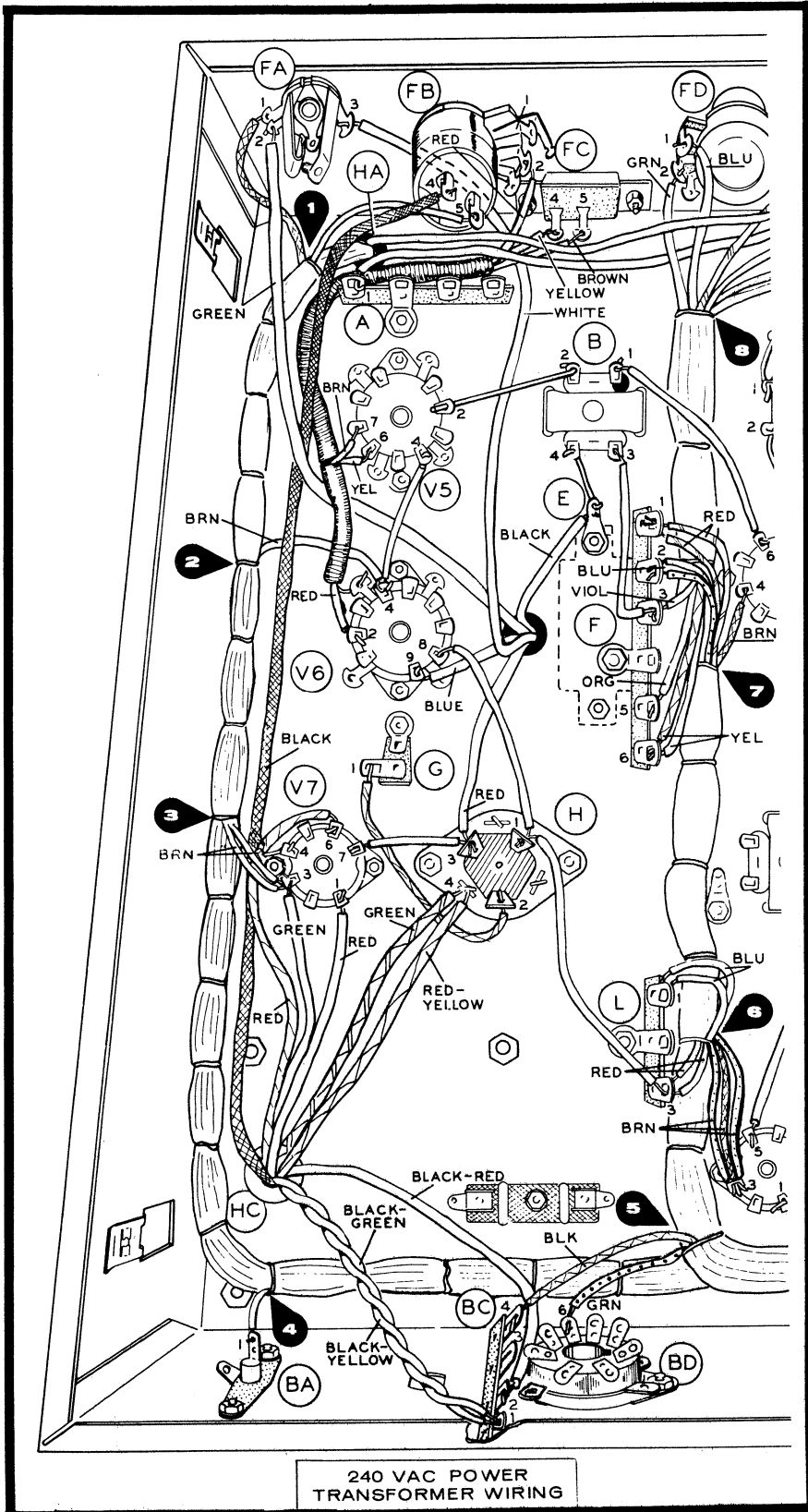

Detail 2A

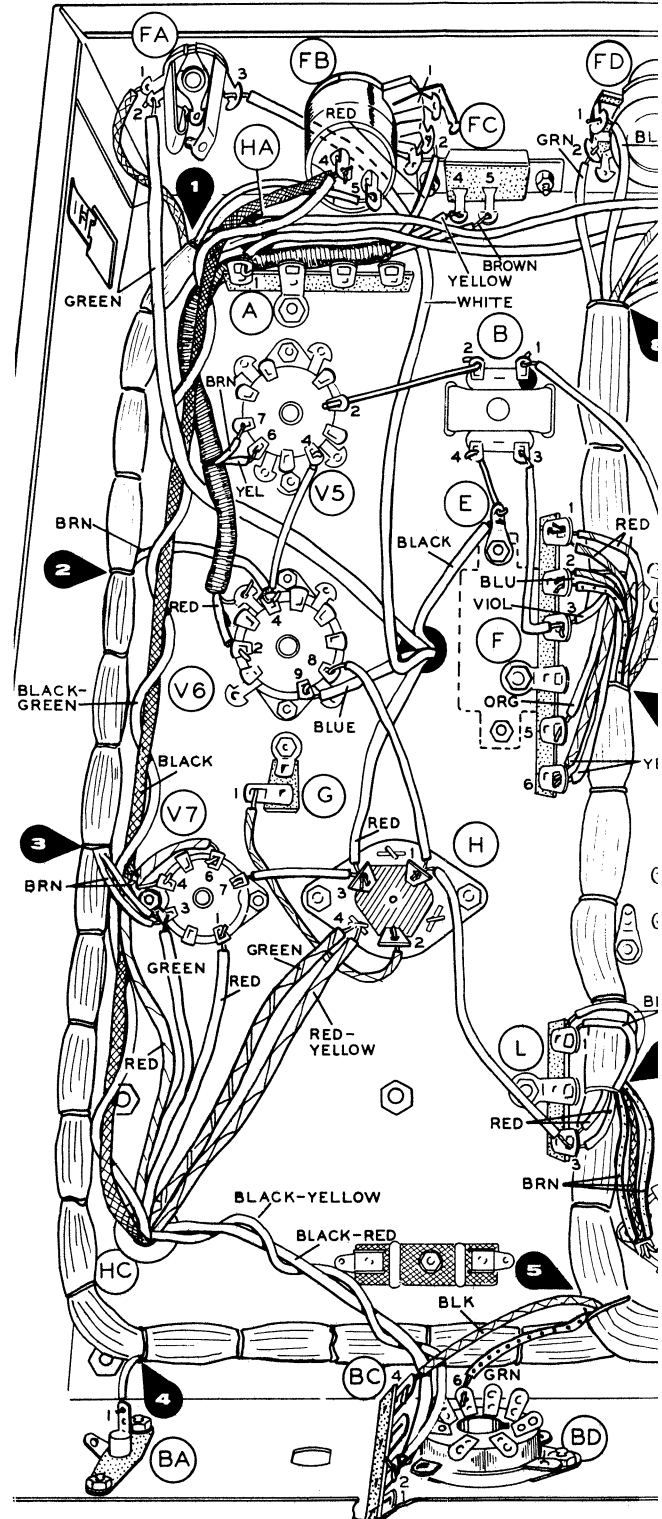

NOTE: THE POWER TRANSFORMER WIRES ARE SHOWN CONNECTED FOR 120 VAC WIRING.





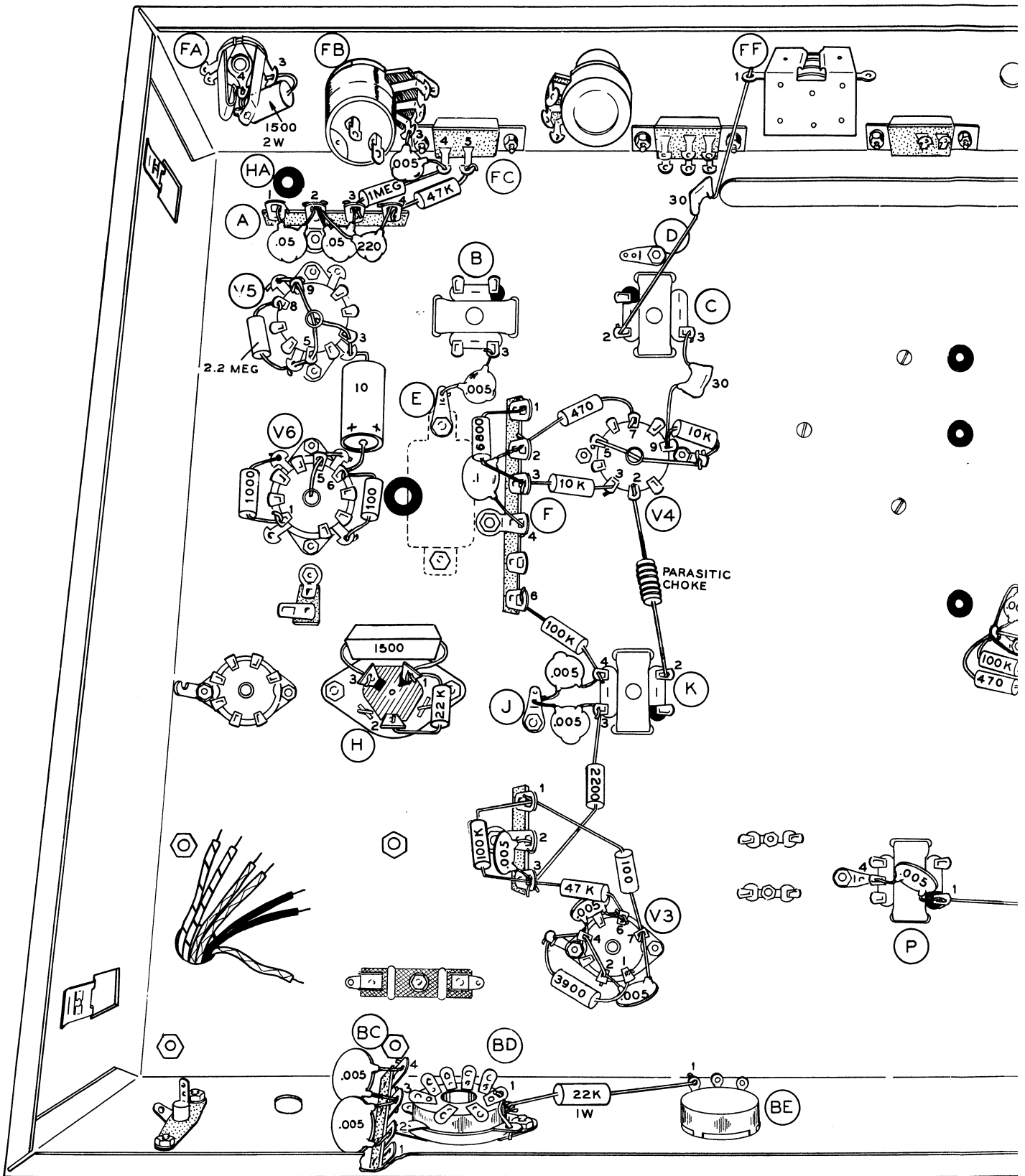

Pictorial 3

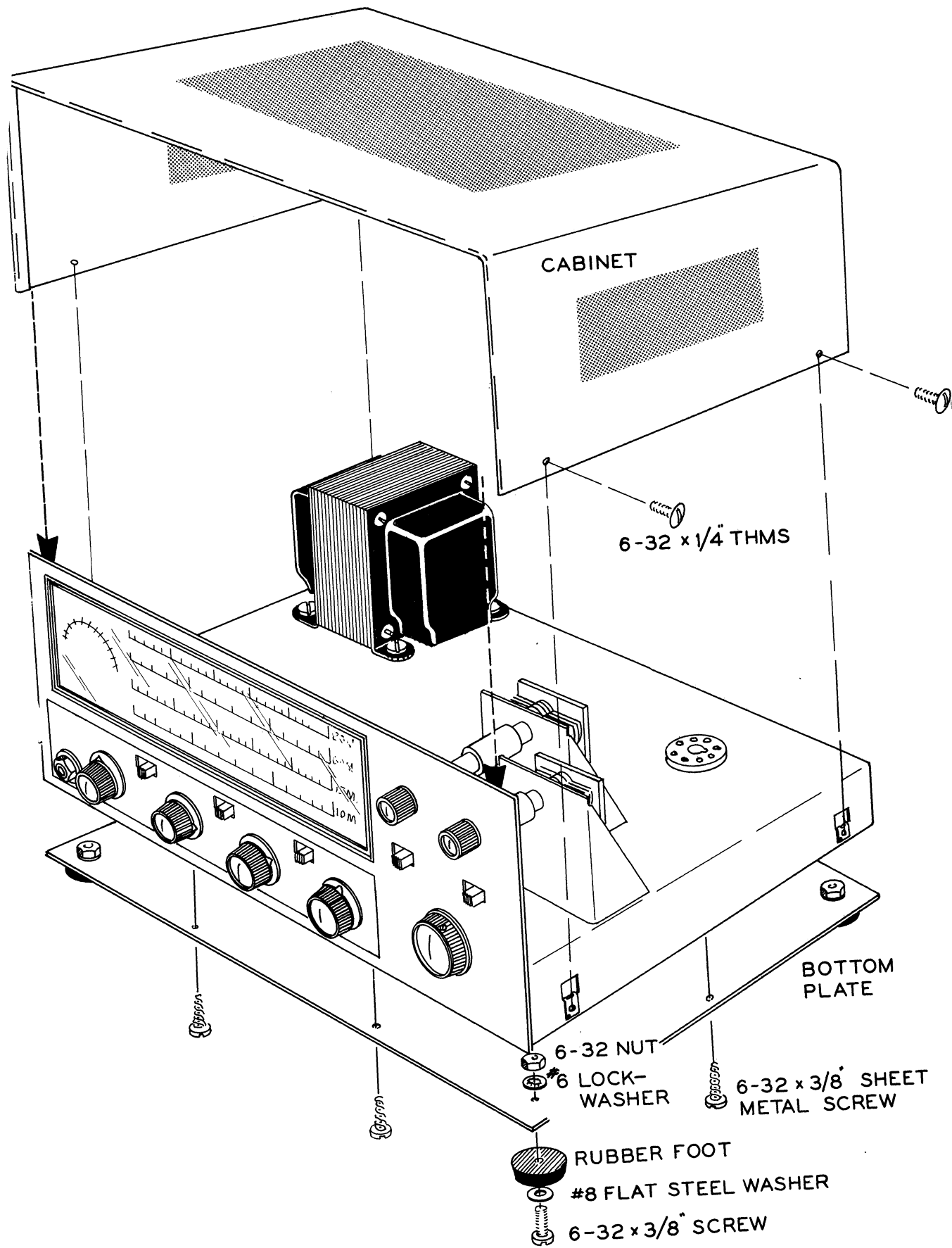
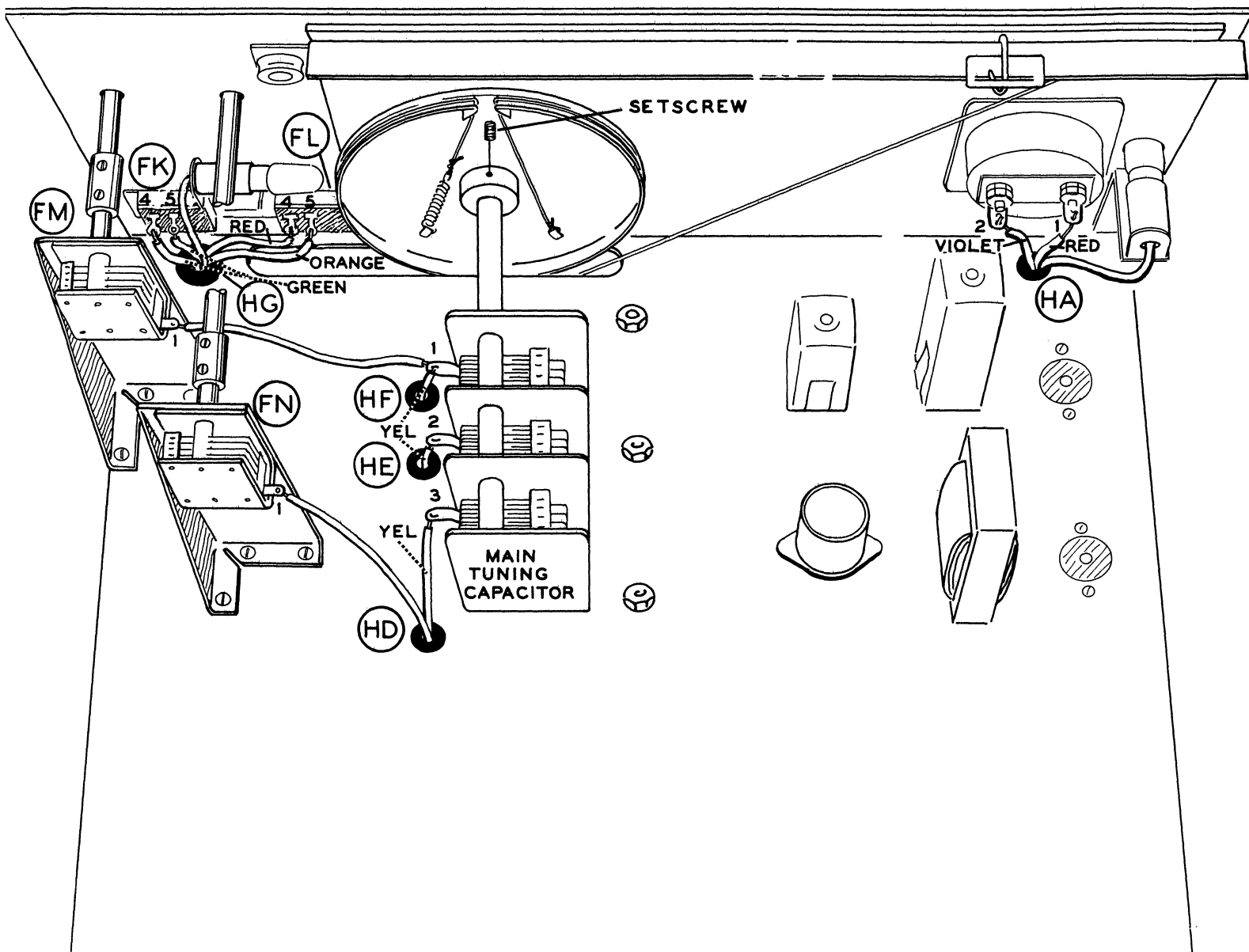

Figure 3



Pictorial 5

# HEATH COMPANY

***THE WORLD'S FINEST ELECTRONIC EQUIPMENT IN KIT FORM***

LITHO IN U.S.A.